

**SAVANNAH STATE UNIVERSITY
NAVAL ROTC UNIT**



MIDSHIPMAN GUIDEBOOK

Midshipman_____

9 January 2009

SAVANNAH STATE UNIVERSITY NROTC UNIT

Subj: MIDSHPMAN GUIDEBOOK

1. Purpose. To promulgate a guidebook for Savannah State University NROTC Unit midshipmen.
2. General. This instruction provides regulations for administration of the Naval Reserve Officers Training Corps (NROTC) Midshipman Company at Savannah State University. It also provides information and guidance required by individual midshipmen.
3. Action. Incoming midshipmen will be issued this instruction during NROTC Orientation Week, and will become thoroughly familiar with the regulations and guidance contained herein. Personnel in receipt of this instruction will ensure currency by promptly entering any changes and corrections as promulgated.

KENT V. FLOWERS

Distribution:
Unit Staff
Midshipman Company

CHAIN OF COMMAND

President of the United States, The Honorable _____
 Secretary of Defense, The Honorable _____
 Secretary of the Navy, The Honorable _____
 Chief of Naval Operations, ADM _____
 Commandant of the Marine Corps, GEN _____
 Commander, Naval Education and Training Command _____
 Commander, Naval Service Training Command _____
 Commanding Officer, SSU NROTC Unit _____

SSU NROTC UNIT PROFESSIONAL STAFF

Professor of Naval Science _____
 Executive Officer _____
 Marine Officer Instructor _____
 Junior/Senior Year Group Advisor _____
 Freshman/Sophomore Year Group Advisor _____
 Assistant Marine Officer Instructor _____
 Supply Technician _____
 Human Resource Assistant _____
 Secretary to the Professor of Naval Science _____

COMPANY STAFF

Abbreviation Key

MCO	Company Commanding Officer
MCMC	Company Master Chief Petty Officer
MXO	Company Executive Officer
MCMNT	Company Mentor Officer
OPSO	Company Operations Officer
PTO	Company Physical Training Officer
MLO	Company Logistics Officer
SUPPO	Company Supply Officer
ADMNO	Company Administrative Officer
PAO	Company Public Affairs Officer
ACADO	Academics Officer

PLATOON STAFF

Abbreviation Key

PLTCDR	Platoon Commander
PLTSGT	Platoon Sergeant
SQDLDR	Squad Leader
FTLDR	Fire Team Leader

STUDENT UNIT STAFF

Semester: _____

MCO _____

MCMC _____

MXO _____

MCMNT _____

OPSO _____

PTO _____

MLO _____

SUPPO _____

ADMINO _____

PAO _____

ACADO _____

PLTCDR _____

PLTSGT _____

MY SQDLDR _____

MY FTLDR _____

STUDENT UNIT STAFF

Semester: _____

MCO _____

MCMC _____

MXO _____

MCMNT _____

OPSO _____

PTO _____

MLO _____

SUPPO _____

ADMINO _____

PAO _____

ACADO _____

PLTCDR _____

PLTSGT _____

MY SQDLDR _____

MY FTLDR _____

STUDENT UNIT STAFF

Semester: _____

MCO _____

MCMC _____

MXO _____

MCMNT _____

OPSO _____

PTO _____

MLO _____

SUPPO _____

ADMINO _____

PAO _____

ACADO _____

PLTCDR _____

PLTSGT _____

MY SQDLDR _____

MY FTLDR _____

STUDENT UNIT STAFF

Semester: _____

MCO _____

MCMC _____

MXO _____

MCMNT _____

OPSO _____

PTO _____

MLO _____

SUPPO _____

ADMINO _____

PAO _____

ACADO _____

PLTCDR _____

PLTSGT _____

MY SQDLDR _____

MY FTLDR _____

STUDENT UNIT STAFF

Semester: _____

MCO _____

MCMC _____

MXO _____

MCMNT _____

OPSO _____

PTO _____

MLO _____

SUPPO _____

ADMINO _____

PAO _____

ACADO _____

PLTCDR _____

PLTSGT _____

MY SQDLDR _____

MY FTLDR _____

TABLE OF CONTENTS

	<u>PAGE</u>
Letter of Promulgation	ii
Record of Changes	iii
Chain of Command/SSU NROTC Unit Professional Staff	iv
Student Unit Staff	v-ix
<u>CHAPTER 1</u>	<u>THE NROTC PROGRAM</u>
101	Program History 1-1
102	Mission and Goals of the Program 1-1
103	The Concept of Honor and The Honor Code 1-1
104	Programs and Scholarships 1-2
105	Summer Training 1-4
106	Naval Science Course Requirements 1-6
107	Commissioning 1-7
108	Service Selection 1-7
109	Disenrollment from the Program 1-8
110	Miscellaneous 1-9
<u>CHAPTER 2</u>	<u>PAY, BENEFITS, AND ALLOWANCES</u>
201	Basic Benefits 2-1
202	Benefits While on Active Duty for Summer Training 2-2
203	Textbook Issue and Control 2-2
<u>CHAPTER 3</u>	<u>SSU NROTC UNIT ORGANIZATION</u>
301	History of the NROTC Unit at Savannah State University 3-1
302	SSU/NROTC Unit Organization 3-1
303	Disseminating Information 3-2
304	Company Organization 3-2
305	Midshipman Officers 3-2
306	Midshipman Non-Commissioned Officers 3-6
	Figure 3-1: Nominal Unit Organization 3-7

TABLE OF CONTENTS (CONTINUED)

<u>CHAPTER 4</u>	<u>PHYSICAL FITNESS</u>	
401	General	4-1
402	Fitness Standards, Guidance, and Responsibilities	4-3
<u>CHAPTER 5</u>	<u>MIDSHIPMAN ACADEMICS</u>	
501	General	5-1
502	Academic Majors	5-1
503	Curriculum Requirements	5-1
504	Academic Workload and Dropping Courses	5-2
505	Attendance Policy	5-2
506	Classroom Conduct	5-3
507	Grades	5-3
508	Academic Warning, Probation, and Leave of Absence	5-3
509	Mandatory Study Program	5-4
<u>CHAPTER 6</u>	<u>CONDUCT AND PERFORMANCE</u>	
601	Standards of Conduct	6-1
602	Aptitude Evaluation	6-3
603	Guidance and Counseling	6-5
604	Performance Review Board	6-6
605	Summer Training	6-6
Table 6-1	Primary and Secondary Evaluators by Billet	6-7
Tab A	Evaluation Report and Counseling Record	
<u>CHAPTER 7</u>	<u>AWARDS</u>	
701	General	7-1
702	Awards Boards	7-1
703	Wear	7-1
704	Order of Precedence and Requirements	7-2
705	Other Awards	7-3

<u>CHAPTER 8</u>	<u>DISCIPLINE</u>	
801	General	8-1
802	Offenses	8-1
803	Reporting Offenses	8-2
804	Handling of Offenses	8-2
805	Counseling	8-2
806	Conduct of Company Review Board	8-3
807	Extra Military Instruction (EMI)	8-4
808	Uniform Code of Military Justice (UCMJ)	8-4
809	Indebtedness	8-5
Tab A	SSU NROTC Student Counseling Record	
<u>CHAPTER 9</u>	<u>MIDSHIPMAN UNIFORMS</u>	
901	General	9-1
902	Uniform Issues	9-1
903	Return of Uniforms	9-1
904	Alterations	9-2
905	Caring For and Wearing Uniforms	9-2
906	Men's Uniforms	9-4
907	Women's Uniforms	9-7
908	Unisex Uniforms	9-10
909	Insignia and Designators	9-11
910	Grooming Standards for Midshipmen	9-14
911	Civilian Attire	9-16
Figure 9-1	Year Group Insignia: Service Dress Blue	9-17
Figure 9-2	Year Group Insignia: Shoulder Boards	9-17
Figure 9-3	Proper Shoulder Board Placement	9-17
Figure 9-4	Year Group Collar Insignia	9-18
Figure 9-5	Midshipman Non-Commissioned Officer Collar Insignia	9-18
Figure 9-6	Midshipman Officer Insignia	9-19

CHAPTER 9 MIDSHIPMAN UNIFORMS (CONTINUED)

Figure 9-7	Midshipman Non-Commissioned Officer Sleeve Insignia	9-19
Figure 9-8	Collar Insignia Placement	9-20
Figure 9-9	Service Dress Blue/White Collar Insignia	9-20
Figure 9-10	Garrison Cap Devices	9-20
Figure 9-11	Proper Placements of Awards and Insignia	9-21

CHAPTER 10 ESSENTIAL KNOWLEDGE FOR NROTC STUDENTS

CHAPTER 1
THE NROTC PROGRAM

101. Program History. The Naval Reserve Officers Training Corps (NROTC) was established by an act of Congress in 1925 to offer interested college students the necessary Naval Science courses required to qualify them for commissions in the Naval Reserve. NROTC Units were established in 1926 at six universities. The Marine Corps joined the program in 1932 offering qualified midshipmen reserve commissions in the United States Marine Corps. The initial program was highly successful and was instrumental in the Navy's expansion from a manpower force of 100,000 officers and men in 1933 to over three and one-half million in 1945. As the United States became the world's leading power, the requirement for a larger regular career officer corps for the Navy became evident. The Holloway Plan, passed in 1946, established the Regular NROTC Program, supplementing the output of the U. S. Naval Academy. In 1972, the Secretary of the Navy authorized 16 women to enroll in the program and in 1992 the first 120 Nurse Corps commissions were authorized. NROTC now consists of the NROTC Scholarship Program and the NROTC College Program, both of which commission graduating Midshipmen as unrestricted officer in the Navy and Marine Corps.

102. Mission and Goals of the Program

a. Mission. To develop future officers mentally, morally, and physically and to imbue them with the highest ideals of duty and loyalty, and with the core values of honor, courage, and commitment in order to commission college graduates as Naval officers who possess a basic professional background, are motivated towards careers in the naval service, and have a potential for future development in mind and character so as to assume the highest responsibilities of command, citizenship, and government.

b. Goals. The primary objectives are to provide students with:

(1) An understanding of the fundamental concepts and principles of Naval Science, national security, and cultural awareness.

(2) Professional knowledge needed by junior commissioned fleet officers.

(3) A strong sense of personal integrity, honor, and individual responsibility.

(4) An educational background which will allow students to perform successfully in their careers, pursue continuing education in a field of application, and further their interest in the naval service.

(5) A culture and mindset of physical fitness.

103. The Concept of Honor and the Honor Code

a. The Concept of Honor. The individual character of the American Sailor and Marine weighs heavily on the calculus of potential conflict. For all the intrinsic excellence of our technology, experience demonstrates that its successful employment in battle continues to depend on the integrity, courage, commitment, and professional excellence of those called upon to bring it to bear in defense of freedom. With ruthless efficiency and finality, the awesome violence of modern warfare distinguishes forces filled with these attributes from those rendered hollow by their absence. Unlike

previous conflicts in our history, technology no longer permits us the luxury of awaiting the first battle to determine whether our forces are ready. The pace of conflict will afford us little, if any, chance to profit from our mistakes.

b. Foundations of Honor. Military units, which often operate under extreme duress, are greased with the oil of absolute trust and fidelity. Honor must be instilled upon future officers during accession training and carried into fleet service.

c. The Honor Code. **A future officer does not lie, cheat, or steal.**

104. Programs and Scholarships

a. National Four-Year Scholarship Program. Students are selected from national competition and are appointed MIDN, U.S. Navy or Marine Corps Reserve, and are on inactive duty except while on cruise. Scholarship students receive the benefits provided by law, which includes college tuition, authorized fees, uniforms, a book stipend, and a monthly subsistence allowance. These students make three summer cruises and, upon graduation, are commissioned as unrestricted line officers in the Navy or Marine Corps or Staff Corps officers in the Navy Nurse Corps, to serve at the pleasure of the President of the United States for a minimum of four years of active duty.

b. Four-Year College Program. College Program NROTC students are civilians who have entered into a contract with the Secretary of the Navy. They are selected by the Commanding Officer, NROTC Unit, from among those students enrolling in the University who apply for the program. College Program students are referred to as Midshipmen, although they do not actually have such appointments. They take the same Naval Science courses, wear the same uniforms and participate in all Unit activities in the same manner as Scholarship students. College Program student benefits include uniforms, Naval Science textbooks, and during their third and fourth years, a monthly subsistence allowance. The monthly allowance is initiated only after College Program students are qualified for Advanced Standing. They participate in one cruise and, upon graduation, are commissioned as officers in the Navy or Marine Corps to serve a minimum of four years active duty.

c. Advanced Standing. The Professor of Naval Science (PNS) may recommend deserving College Program students for advance standing. Selection is based on academic performance and aptitude evaluation. Final approval is vested in the Naval Service Training Command.

d. National Two-Year Scholarship or Two-Year College Program. Students are selected through national competition from applicants having at least two years of academic study remaining for a Baccalaureate Degree. Application for this program is made early in the fall of the Second (sophomore) year in college. Midshipmen already in the NROTC program are not eligible to apply. Selected applicants report to the Naval Science Institute (NSI) at Newport, RI, in June, after completing their second year of college (or after the third year of a five-year curriculum). NSI is a six-week course in Naval Science and military training which covers the material of the first two years of NROTC. Upon completion of NSI a Two-Year Scholarship Program student reports to their host unit as a Midshipman Second Class.

e. Historically Black College or University (HBCU) Scholarship Program. The HBCU Scholarship Program was established to attract higher enrollment at HBCUs throughout the country. Eligibility is open to high school students of any race or ethnicity who have yet to demonstrate performance in a college

environment or to college students who have completed one but less than two semesters of course work at a university, achieving a GPA of 2.75 (4.0 scale) with no grade below a "C" in all courses attempted. The HBCU scholarship covers tuition, fees, textbooks, and uniforms for up to 4 academic years.

f. Nurse Corps Option. Since 1991, Nursing has been allowed as a major for NROTC midshipmen. Nursing Option students are required to take four of the eight naval science classes and to participate in all Unit activities, except where such participation conflicts with required clinicals. Nurse Option Midshipmen must apply to Nursing School by the end of their sophomore year. Upon graduation, students are commissioned as Ensign, Nurse Corps, United States Navy. This option is open to both National and HBCU scholarship recipients.

g. Marine Corps Option. Midshipmen may apply for Marine Corps Option at the time of initial application (scholarship or College Program Students) or after one full year of academic studies but no later than the end of their junior year. In order to transfer from Navy Option to Marine Option, students must meet all the minimum physical and academic requirements (consult with the Marine Officer Instructor for requirements). Once deemed satisfactory, the student's option change request is submitted via the MOI. All Marine Corps Option Midshipmen must complete Marine Corps Officer Candidate School prior to commissioning.

h. Extended Benefits Option. Scholarship and College Program Students may pursue fields of study requiring more than 4 years for a baccalaureate degree whose total workload of degree course requirements, Navy specified course requirements, and Naval Science courses exceed a normal four year workload (15-18 hours/semester). Students in these fields may apply for one or two additional semesters of scholarship benefits and must do so at the end of their sophomore year. These extra semesters of benefits will result in additional obligation, and those students denied extra benefits are placed on Leave of Absence (discussed in Article 508.) Consult your advisor regarding this option if you feel you may require it.

i. Naval Science Student. Naval Science Students are civilian university students who show interest in the NROTC program and may enroll in Naval Science classes. They have no official connection with the Navy, nor are they required to participate in drills, cruises, or NROTC activities.

j. Seaman to Admiral 21 (STA-21)

(1) Definition. The STA-21 is a commissioning program that provides an opportunity for highly motivated fleet Sailors to earn a commission. These Sailors must earn a Baccalaureate Degree within 36 months.

(2) Status of Officer Candidate (OC) Students. Navy STA-21 students are designated as Officer Candidates and participate in all Company activities while completing the STA-21 program. All STA-21 Officer Candidates are assigned for duty as full-time students in rigorous and demanding curricula. They are not given duties as enlisted personnel nor assigned in any manner inconsistent with NROTC midshipmen. Although considered Officer Candidates, STA-21 students retain their enlisted status for pay and advancement purposes. STA-21 students receive full pay and allowances, retain all privileges and benefits due active duty members, and are subject to the Uniform Code of Military Justice (UCMJ). They wear the uniform issued to them at NSI and are issued Military Identification Cards specifying their status as Officer Candidates. Officer Candidates are advised by one of the Navy YGAs and must report to the NROTC

unit during semester breaks.

(3) Specific guidance on the administration of STA-21 students is found in the Regulations for Officer Development.

k. Marine Enlisted Commissioning Education Program (MECEP)

(1) Definition. The MECEP is a college program for specially selected Marine Corps enlisted personnel leading to a baccalaureate degree in four years or less and a commission in the U.S. Marine Corps.

(2) Status of MECEP Students. MECEP students are active duty enlisted Marines who, during their tour of duty under instruction, retain their active duty status. As such, they receive full pay and allowances, retain all privileges and benefits accruing to active members, and are subject to the Uniform Code of Military Justice (UCMJ). While assigned to the NROTC unit, MECEP students are carried on the roster of the nearest Marine Corps activity but are under the administrative and disciplinary jurisdiction of the Professor of Naval Science. MECEP students wear the Marine enlisted uniform and are referred to by their enlisted rank.

(3) Specific guidance on the administration of MECEP students is found in the Regulations for Officer Development.

105. Summer Training

a. Training periods with operational forces of the U. S. Navy (commonly known as 'Summer Cruises') give midshipmen the opportunity to gain experience through the practical application of Naval Science. Summer cruises normally are three to four weeks in length.

(1) Midshipman Third Class Cruise. Career Orientation and Training for Midshipmen (CORTRAMID) is a combined orientation period for scholarship students. This cruise is normally conducted between the student's first and second years at either San Diego, CA or Norfolk, VA. One week is spent with each of the major communities including: Naval Aviation, Naval Submarine Service, Navy Surface Warfare, and the Marine Corps. The objective of this cruise is to expose midshipmen to each community that NROTC commissions to, so that midshipmen can make a more informed decision about what area of the Naval Service they would like to enter. Nurse Corps Option midshipmen do not attend CORTRAMID, but instead conduct at-sea training with an operational ship's Medical Department.

(2) Midshipman Second Class Cruise. This cruise is normally made between the student's second and third years on board an operational fleet unit. Midshipmen assume the duties of enlisted personnel and train on board their vessel with enlisted crewmembers. Midshipmen who have not yet attended CORTRAMID may do so in lieu of their second class cruise if billets are available. Nurse Corps Option midshipmen who did not complete their Third-Class (At-Sea) cruise will do so between their second and third years.

(3) Midshipman First Class Cruise. This cruise is normally completed between the student's third and fourth years, and is conducted on a surface ship, submarine, or aviation unit. Midshipmen are trained as junior officers and given associated responsibilities. The goal of this cruise is for the senior midshipman to experience their chosen warfare specialty and gain a clear understanding of the responsibilities a junior officer in that warfare field. Nurse Corps Option midshipmen will conduct first class training at a naval hospital, either in San Diego, CA or Portsmouth, VA.

(4) Foreign Exchange Cruise. The Foreign Exchange Cruise program is designed to promote an exchange of professional, cultural, and social experiences between Midshipmen in the United States Navy and Midshipmen of foreign navies. A limited number of exemplary Midshipmen First Class are selected to conduct their First Class Cruise with a foreign navy in lieu of the normal First Class training cruise. Interested students should see the Summer Cruise Coordinator early in their junior year to inquire about this training, as requirements, circumstances, and availabilities change often.

b. Marine Corps Option Summer Training. Marine Option Scholarship students attend CORTRAMID for their first summer training session. In their second summer, they report to the Marine Mountain Warfare Training Center in Bridgeport, CA to train for mountain and cold weather warfare. Their final summer of training is at the Marine Corps Officer Candidate School in Quantico, Virginia. This training concentrates on leadership development and screening of candidates for commissioning. Students must complete this training with passing grade to become a Marine Officer. Inquiries regarding Marine Summer Training should be directed to the Marine Officer Instructor or Assitant Marine Officer Instructor.

c. Preparation for Training. Detailed instructions for the various training periods are promulgated each spring semester by the Summer Cruise Coordinator.

d. Uniforms and Equipment. Clothing and equipment requirements for cruises will be promulgated each year by Commander Naval Service Training Command, and published by the Summer Cruise Coordinator. It is particularly important that Midshipmen participating in a cruise possess a complete set of uniforms and gear prior to reporting for the cruise. Each student will be notified by the Summer Cruise Coordinator regarding required equipment for their cruise.

e. Waivers and Postponements. Under extraordinary circumstances, required summer training may be waived (Third- and Second-Class) or postponed (First-Class). See the Summer Cruise Coordinator for more information.

f. Academic Year Cruise. Academic Year Cruises are conducted during academic semesters and are the exception, not the rule. Billeting for these cruises is very limited. See the Summer Cruise Coordinator for details.

106. Naval Science Course Requirements. Midshipmen in a four-year academic program will normally take Naval Science classes as outlined below. Exceptions to this plan must be approved by the Professor of Naval Science.

Freshman Year

FIRST SEMESTER			SECOND SEMESTER		
Course	No.	Cr.	Course	No.	Cr.
Naval Lab	NSCI 4050	0	Naval Lab	NSCI 4050	0
Introduction to Naval Science	NSCI 1001	2	Seapower & Maritime Affairs.	NSCI 1002	3
TOTAL		2	TOTAL		3

Sophomore Year

FIRST SEMESTER			SECOND SEMESTER		
Course	No.	Cr.	Course	No.	Cr.
Naval Lab	NSCI 4050	0	Naval Lab	NSCI 4050	0
Leadership and Management	NSCI 2002	3	Navigation	NSCI 3003	3
TOTAL		3	TOTAL		3

Junior Year (Navy Option)

FIRST SEMESTER			SECOND SEMESTER		
Course	No.	Cr.	Course	No.	Cr.
Naval Lab	NSCI 4050	0	Naval Lab	NSCI 4050	0
Naval Ship Systems I	NSCI 2102	3	Naval Ship Systems II	NSCI 4001	3
TOTAL		3	TOTAL		3

Junior Year (Marine Corps Option)

FIRST SEMESTER			SECOND SEMESTER		
Course	No.	Cr.	Course	No.	Cr.
Naval Lab	NSCI 4050	0	Naval Lab	NSCI 4050	0
Evolution of Warfare	NSCI 3101	5			
TOTAL		5	TOTAL		0

Senior Year (Navy Option)

FIRST SEMESTER			SECOND SEMESTER		
Course	No.	Cr.	Course	No.	Cr.
Naval Lab	NSCI 4050	0	Naval Lab	NSCI 4050	0
Naval Ops & Sea	NSCI 3004	3	Leadership & Ethics	NSCI 4104	3
TOTAL		3	TOTAL		3

Senior Year (Marine Corps Option)

FIRST SEMESTER			SECOND SEMESTER		
Course	No.	Cr.	Course	No.	Cr.
Naval Lab	NSCI 4050	0	Naval Lab	NSCI 4050	0
Amphibious Warfare	NSCI 4102	5	Leadership & Eth	NSCI 4104	3
TOTAL		5	TOTAL		3

107. Commissioning. NROTC Scholarship, College Program, STA-21, and MECEP students are normally commissioned in conjunction with their university graduation. They are commissioned as Ensigns in the Navy or as Second Lieutenants in the Marine Corps, and serve for a minimum of four years of active duty service. Midshipmen opting for service in Aviation, Submarine Warfare, or Nuclear Surface Warfare Specialties will normally serve for five to eight years after earning a commission because of the extensive training received in each of these fields.

108. Service Selection

a. Navy. Ensigns will be assigned in one of the following communities prior to their commissioning:

(1) Surface Warfare. Midshipmen choosing the surface warfare community will be assigned directly to a ship after commissioning. After completing warfare qualifications, they are assigned to a second surface vessel, where they will further their warfare training.

(2) Nuclear Submarine and Surface Warfare. A Midshipman may apply for the nuclear power program and if accepted, will receive the current Nuclear Officer Accession Bonus upon acceptance. Upon receiving their commissions, applicants for the submarine community attend the Navy's Nuclear Power School in Charleston, SC and applicants for the nuclear surface community will be assigned to a fleet ship prior to attending Nuclear Power School. Upon completion of the nuclear power pipeline, they will be assigned to a nuclear powered aircraft carrier. For further information contact the Nuclear Power Officer.

(3) Aviation. If physically qualified, Midshipmen may request Pilot or Naval Flight Officer Training. Initial training will take place at Naval Aviation Schools Command in Pensacola, FL after commissioning.

(4) Restricted Line/Staff Corps. Normally, Midshipmen may be offered a Navy commission in a Restricted Line or Staff Corps community only if not physically qualified for the Unrestricted Line. For further information contact your advisor.

b. Marine Corps. Upon graduation, newly commissioned Second Lieutenants will attend The Basic School at Quantico, VA for 23 weeks before assignment to a Marine unit, specialist military school, or Marine aviation training. For further information, contact the Marine Officer Instructor.

109. Disenrollment from the Program

a. Drop on Request (DOR). A scholarship student may voluntarily drop from the NROTC Program without obligation at any time prior to starting the second year of college. A College Program student may voluntarily drop the NROTC Program without obligation prior to accepting Advanced Standing.

b. Physical/Medical. Multiple failures of the Physical Fitness Assessment, or failure during the senior year, may be grounds for disenrollment. For disqualifying medical conditions, the Chief of the Bureau of Medicine and Surgery (BUMED) will inform the member and the unit.

c. Academic. Repeated academic deficiency may be grounds for the student to be disenrolled.

d. Aptitude.

(1) The PNS shall recommend disenrollment of any NROTC student who has demonstrated a lack of officer aptitude as to make further retention unjustified.

(2) Inaptitude disenrollment recommendations may include, but are not limited to, any of the following:

(a) Unsatisfactory leadership qualities.

(b) Unsatisfactory acceptance of responsibility.

(c) Inability to meet physical conditioning standards or swimming qualification requirements.

e. Disciplinary. Disciplinary disenrollment recommendations may include, but are not limited to, any of the following:

(1) Major breach of Navy discipline.

(2) Criminal and/or moral offenses deemed to be disqualifying by the PNS, including violation of standards of honor expected of an NROTC Midshipman.

(3) Cumulative unsatisfactory disciplinary record.

(4) Refusal to accept commission (may result in requirement to serve four years active duty enlisted service).

(5) Alcohol or drug abuse, or alcohol/drug related incidents as addressed in OPNAV 5350.4 (series).

f. Active Enlisted Service (AES). Any student who has accepted a service obligation and is disenrolled for reasons other than physical disqualification is subject to call to AES or recoupment of all money paid, based on the needs of the Navy.

g. STA-21 and MECEP students. STA-21 students are required to serve five years from disenrollment date or fulfill their existing contracts, whichever is longer. MECEP students disenrolled from the NROTC program will be re-assigned to the Fleet Marine Force to complete obligations under his or her existing contract.

110. Miscellaneous

a. Travel/Residence in a Foreign Country. Travel to a foreign country during summer cruises is likely. To take advantage of this program midshipman must have a valid passport. Students also have the opportunity to study abroad during the school year and once again, are required to have a passport to participate in this program.

b. Appointment to the United States Naval Academy. NROTC Midshipmen are selected yearly for an appointment to the United States Naval Academy. Selection is based on scholastic aptitude, a Professor of Naval Science recommendation, and a physical examination is required. Contact your Year Group Advisor if you have any questions.

CHAPTER 2
PAY, BENEFITS, AND ALLOWANCES

201. Basic Benefits

a. Educational Expenses. Scholarship Midshipmen receive college tuition, authorized fees, stipend of \$250 - \$400, and a book stipend of \$375 per semester for the academic years stipulated in their scholarship award, not to exceed 40 months for four years or 20 months for the third and fourth years. Benefits are extended to cover summer school only if summer school attendance will advance the commissioning/graduation date of a midshipman. The Year Group Advisors should be contacted for details.

b. Subsistence. Scholarship and Advance Standing College Program Midshipmen are entitled to a monthly subsistence. The allowance is paid during full time enrollment of classes for a period of not more than 10 months per academic calendar year. The allowance is not paid during the cruise period. See the Human Resources Assistant for questions.

c. Uniforms. All midshipmen are issued a complete set of uniforms upon reporting to the NROTC Unit. These uniforms must be cared for and certain items must be returned to the unit upon commissioning. Naval officers are also entitled to a one-time uniform allowance when commissioned. See the Supply Technician for questions.

d. Travel. Midshipmen may be required to travel for certain events or to fulfill certain requirements, such as summer training, field trips, etc. When travel is required, the HRA will coordinate travel orders. See the HRA for questions.

e. Travel Cost Reimbursement. Scholarship and Advance Standing College Program Midshipmen are reimbursed for official NROTC travel, such as Summer Cruises. A travel claim voucher must be completed within five days of return from travel. Contact the HRA for more information.

f. Expenses not paid by the Government. The government does not pay for:

- (1) Room, board, and everyday travel except when on active duty.
- (2) Expendable school supplies, such as pencils and paper.
- (3) Fees required to be paid which are refunded.
- (4) Items for long-term benefit, such as computers or calculators.
- (5) Tuition payments and fees for summer school made necessary by academic deficiencies or failures.
- (6) Fees for elective courses such as scuba diving, sky diving, and skiing.

202. Benefits While on Active Duty for Summer Training

a. Basic Pay. NROTC midshipmen attending summer or at-sea training are paid at the same rate as U.S. Naval Academy Midshipmen. They will receive 80 percent of their estimated basic pay prior to summer training. The remainder will be paid upon their return and completion of a travel claim with actual

dates of summer training. Midshipmen are not entitled to special or incentive pay.

b. Travel Allowances. A plane ticket is provided from Savannah or the home of record to the cruise reporting station and from the cruise detachment station to Savannah or the home of record. See the Summer Cruise Coordinator or the HRA for questions.

c. Insurance. Government health and life insurance cover NROTC midshipmen only while on active duty for summer training. They are insured for up to \$400,000 term life insurance unless they elect less coverage. A nominal life insurance premium will be deducted from their active duty pay. Also, Midshipmen participating in command sponsored high risk training (sailing, pistol team practice, physical training or swimming) are not covered in the case of injury. Midshipmen should verify that they are covered by their parent's insurance or obtain a school insurance policy that adequately covers them in case of injury. Midshipmen who sustain injuries while travelling in a GSA vehicle to and from command directed events may seek reimbursement for medical costs under the Department of Labor Workers Compensation by submitting forms cal or cal6. If a midshipman suffers an injury during summer training, they are covered by Tricare which will be filed through Military Medical Support Office (MMSO). Midshipmen are also covered for qualifying medical examinations and required immunizations at a Military Treatment Facility (MTF) only. Students are cautioned to ensure they maintain adequate health insurance coverage for those times when they are not in a line of duty status. Specific information is available from the HRA.

203. Textbook Issue and Control

a. Naval Science Texts. These texts are issued to all NROTC students. The texts must be returned at the end of each semester to the appropriate Naval Science course instructor in the same condition it was received.

b. Non-Naval Science Texts and Course Materials. Scholarship and Advance Standing College Program Midshipmen will receive a book stipend of \$375 per semester for the purchase of non-naval science textbooks. These textbooks and materials become the property of the student to retain or sell back to the University at their discretion.

CHAPTER 3
SSU NROTC UNIT ORGANIZATION

301. History of the NROTC Unit at Savannah State University. The Naval ROTC Unit at Savannah State University (then Savannah State College) was established on 22 September 1971 with an enrollment of forty-one Midshipmen. The first four officers, three Navy Ensigns and one Marine Corps Second Lieutenant, were commissioned three years later. In 1974, Armstrong Atlantic State University (then Armstrong Atlantic State College) signed a cross-town enrollment agreement with Savannah State University to allow students at Armstrong Atlantic State University to participate in the NROTC program at Savannah State University. In December 1977, the first "cross-town" Midshipman from Armstrong Atlantic State University was commissioned.

302. SSU NROTC Unit Organization

a. Military Organization. The NROTC program is administered by Commander, Naval Service Training Command (NSTC). NSTC is based in Great Lakes, Illinois and exercises military command of the NROTC Unit. The Commanding Officer of the Unit is assigned by the Department of the Navy and is the senior commissioned officer, Navy or Marine Corps, assigned to permanent duty with the Unit.

b. University Organization. The NROTC Unit constitutes the Department of Naval Science under the control of the Dean of Science and Technology for Savannah State University. The Commanding Officer of the Unit is appointed by the University to serve as Professor of Naval Science and Department Chair. The Executive Officer is appointed Associate Professor of Naval Science and other Navy and Marine Corps officers assigned as instructors receive University appointments as Assistant Professors of Naval Science. Enlisted Navy and Marine personnel assigned to the unit staff are considered University staff as well.

c. Role of the Marine Officer Instructor (MOI). The MOI is responsible for the conduct of the Naval Science Laboratory class and acts as the primary advisor to the Student Unit Staff. The MOI is responsible for assigned Naval Science courses (NSCI 3101, 4102 and 4050) and advises all Marine Option midshipmen and MECEP students regarding academic and professional matters.

d. Role of the Assistant Marine Officer Instructor (AMOI). The AMOI is responsible to the Commanding Officer for the general military discipline of the Unit. Additionally, the AMOI may assist in conducting drill and coordinating unit events as needed.

e. Role of the NROTC Year Group Advisors (NYGA). The NYGAs are responsible for the conduct of their assigned Naval Science courses and advise all Navy Option Midshipmen and Officer Candidates assigned to them. NYGAs also act as professional, academic, and personal counselors for all students at the unit.

f. Administrative Personnel. The overall supervision of the administrative office is assigned to the Unit Executive Officer. The Secretary to the PNS is a university employee.

g. Midshipman Records. The Human Resources Assistant (HRA) maintains records on each student at the unit concerning medical and dental information, pay, and travel. The HRA should be consulted with any questions regarding these records.

h. Supply. The Supply Technician is charged with ensuring the accuracy and completeness of the unit's uniform and equipment inventory. A midshipman with any uniform-related questions should consult this staff member.

303. Disseminating Information. Information for the Company will be passed via mailbox, email, or at unit musters. The Company Commanding Officer shall ensure the Company mailbox is checked daily, and that word is passed completely and efficiently to every student. Each student is responsible for checking his/her e-mail and being attentive at musters to ensure that they receive and act on important information.

304. Company Organization

a. The Unit. The Midshipmen Company is comprised of two platoons, each made up of three to five Squads. This composition may change, depending on the size of the unit. In addition, student unit staff members make up a separate platoon. The Company CO is in charge of both groups.

b. Company Staff. The Company Staff (Co Staff) consists of those students chosen each semester by the unit staff and charged with a particular duty or set of duties. Student unit staff billets may be added, merged, or removed as deemed necessary by the PNS. The Co Staff members are not placed in regular ranks, but form a separate group under the authority of the MXO.

305. Midshipman Officers

a. Appointment. Midshipman officers are appointed by and serve at the pleasure of the Commanding Officer, NROTC Unit. Appointments for the following academic semester are made in the previous semester from recommendations made by a billet selection board composed of Unit Staff Officers. Once appointed, the Co Staff completes a full turnover during the last week of each semester.

b. Criteria. Officer appointments are an integral part of NROTC training. Appointments to Company billets are changed each semester to provide the maximum opportunity for Midshipmen to gain leadership experience through service in command and staff billets. Selection criteria include, but are not limited, to the following:

- (1) Demonstrated Leadership Ability/Past Billets Held
- (2) Naval Science Aptitude
- (3) GPA
- (4) Physical Readiness

c. Responsibility. It is essential that each Midshipman Officer be aware of the responsibility inherent in the special trust and confidence bestowed upon them by the appointment. Performance of assigned duties significantly impact subordinate Midshipmen. As a leader, the Midshipman Officer sets an example for juniors to follow. Midshipman Officers are responsible for meeting and maintaining the high standards required of commissioned Naval Officers in the Armed Forces of the United States. Midshipman Officers are specifically charged with the responsibility for:

- (1) Knowing their assignments and responsibilities.

(2) Knowing the midshipmen for whom they are responsible, and with whom they have to deal in the execution of their duties, and doing the utmost to promote their military and academic welfare.

(3) Carrying out with precision and dispatch the proper orders of midshipmen senior to them.

(4) Issuing appropriate and timely orders to those midshipmen junior to them.

(5) Maintaining proper discipline during drill periods and other events involving the Company.

(6) Ensuring that midshipmen observe all applicable Naval regulations and customs.

(7) Ensuring that orders are executed as intended.

(8) Observing outstanding as well as unsatisfactory performance of subordinates for purposes of giving credit or taking corrective action as appropriate.

(9) Setting the example in leadership, observing military regulations, courtesy, and customs and maintaining a neat, well-groomed appearance in civilian and military attire.

d. Midshipman Officer Ranks. Midshipman Officer ranks for the corresponding billets are as follows:

<u>Officer Assignment</u>	<u>Midshipman Rank</u>	
	<u>Navy Option</u>	<u>Marine Option</u>
Company Commanding Officer	Captain	Colonel
Company Executive Officer	Commander	Lieutenant Colonel
Company Mentor	Commander	Lieutenant Colonel
Operations Officer	Lieutenant Commander	Major
Administrative Officer	Lieutenant	Captain
Platoon Commander	Lieutenant	Captain
Logistics Officer	Lieutenant Commander	Major
Supply Officer	Lieutenant	Captain
Physical Training Officer	Lieutenant Junior Grade	First Lieutenant
Drill Team Commander	Lieutenant Junior Grade	First Lieutenant
Public Affairs Officer	Ensign	Second Lieutenant

A midshipman assigned to one of the above billets is addressed as "MIDN____" or "Midshipman-(MIDN Rank) _____". For example, the MCO may be addressed as either "MIDN _____" or as "Midshipman Captain _____".

e. Officer Billet Descriptions

(1) Company Commanding Officer (MCO). The senior member of the Midshipman Company, the Company Commander works directly with the MOI and ensures execution of all operational orders.

(a) Responsibilities. The MCO is responsible for all that the Company does or does not do.

(b) The MCO reports directly to the Commanding Officer of SSU/NROTC Unit, and is advised primarily by the MOI. However, the MCO may seek advice from any member of the unit staff.

(2) Company Executive Officer (MXO). The Company Executive Officer is the principal assistant and advisor to the MCO. He or she performs duties in the Co Staff similar to those of a Chief of Staff or Executive Officer in an Operational Command.

(a) Responsibilities. The MXO is charged with the responsibility for the supervision of the Midshipman Company Staff, for the efficient and prompt response of the Staff, for coordinating the Midshipman Company efforts and, when applicable, for directing subordinates in the name of the MCO. During the MCO's temporary absence, and when so authorized, the MXO substitutes for the MCO and directs actions in accordance with the MCO's policies. He or she is prepared to assume command of the Company at any time. The MXO collects weekly reports from each Staff Officer. The MXO is also in charge of staff functions such as meetings.

(b) The MXO reports directly to the MCO.

(3) Company Mentor (MCMNT). The Company Mentor is responsible for the morale and welfare of the members of the Company.

(a) Responsibilities. The Company Mentor will work with the CO of SSU NROTC Unit and MCO to ensure that troop morale is at acceptable levels. He or she will assist the MCO in running and maintaining the Mentor Program.

(b) The Midshipman Company Mentor will ensure that each 4/C midshipman will be assigned a 2/C midshipman as their mentor. Initially, each 3/C midshipman will be assigned a 1/C midshipman as their mentor. The mentor relationship between the two midshipmen will remain in effect without interruption from semester to semester.

(c) The Company Mentor reports directly to the MXO while working closely with the MCO.

(4) Operations Officer (OPSO). The Operations Officer is responsible for ensuring the smooth and efficient execution of all Company operations, including weekly Leadership Lab. The OPSO assists in the formulation of the Company schedule and ensures that all planning and logistical concerns are met.

(a) Responsibilities. A major task for the OPSO is overseeing the progress and accomplishment of all assigned Operational Orders/Letters of Instructions (OPORDS/LOIs). Additionally, the OPSO must continually update the Company schedule and explore contingency plans in order to execute evolutions smoothly. The OPSO is also responsible for keeping the Unit Staff informed of the Company schedule. The OPSO and MXO shall meet regularly with the MOI to discuss upcoming events and other Company issues.

(b) The OPSO reports directly to the MXO.

(5) Administration Officer (ADMINO). The ADMINO is generally responsible for the administrative records and information flow within the Company. The ADMINO also maintains all Company records and associated databases detailing Company duties and functions.

(a) Responsibilities. The ADMINO is in charge of receiving, evaluating and forwarding all chits, overseeing the evaluation process for both mid-semester and final evaluations, consolidating and publishing company award nominations, preparing certificates for company awards presentations and tracking which students received which award. The ADMINO also is responsible for assisting the Unit Human Resource Assistant (HRA) by ensuring students report to fulfill administrative requirements when requested. Additionally, the ADMINO may be tasked with other administrative duties by the unit staff.

(b) The ADMINO reports directly to the MXO.

(6) Logistics Officer (LO). The LO is primarily responsible for managing Company funds and ensuring that all Company supply needs are met. The Supply Officer (SUPPO) will assist the LO.

(a) Responsibilities. The LO must orchestrate the collection of Company Activities Fees, and present monthly budget reports to the MCO. In addition, the LO oversees the maintenance of the Company spaces. The LO creates and presents Company budgets to the Unit Staff via the MXO and MCO. Furthermore, the LO must oversee the budgeting requirements of all OPORDS/LOIs and coordinate the associated disbursement of funds. The LO coordinates with the MXO to ensure all supply related items are purchased and managed efficiently.

(b) The LO reports directly to the MXO.

(7) Academics Officer (ACADO). The ACADO is responsible for overseeing the Mandatory Study Program (MSP) and identifying resources that will enhance the Midshipman Company's academic performance.

(a) Responsibilities. The ACADO is responsible for ensuring that all students assigned to the MSP are properly notified. The ACADO also ensures that MSP students adhere to the Unit's MSP policy and review each student's MSP mandatory log to ensure the assigned number of hours is completed. The ACADO shall report violations of the MSP policy to the Command Academics Officer.

(b) The ACADO reports directly to the Command Academics Officer.

(8) Physical Training Officer (PTO). The PTO is responsible for the safe conduct of all physical training evolutions.

(a) Responsibilities. The PTO is responsible for ensuring that all students conduct proper warm-ups and cool downs during all Physical Training (PT) sessions. The PTO will ensure that all students are graded accurately on the PRT and PFT. He or she will implement and monitor a remedial PT program for midshipmen who do not meet NROTC standards. Additionally, the PTO will disseminate pertinent information to the midshipmen regarding health and fitness.

(b) The PTO reports directly to the OPSO.

(9) Public Affairs Officer (PAO). The PAO is generally responsible for the public representation of the Company through publications, letters, displays, and phone calls.

(a) Responsibilities. The PAO works closely with the unit staff to regularly publish the unit's newsletter, ensure that photos are taken of selected unit events and activities, and maintain records of unit events and activities to propagate the command operations report.

(b) The PAO reports directly to the OPSO.

(10) Platoon Commander (PLTCO). The PLTCO works directly with the student staff in the execution of the Company's operational orders. Ultimately, the PLTCO is responsible for all that the platoon does or fails to do.

(a) Responsibilities. The PLTCO is the final supervisory point for a platoon's operations orders and overall function. The Platoon Commander shall supervise the Squad Leaders and ensure that all students required to muster or attend an event have done so. Ultimately, the PLTCO will be charged with the supervision and welfare of all students at the unit not assigned as staff members. Squad Leaders are the exception to this.

(b) The Platoon CO will normally report directly to the MXO. The PLTCO will be renamed the Company Commander and will supervise the designated number of Platoon Commanders if the Company/Platoon format is used. The duties of Squad Leaders and Fire Team Leaders are unchanged.

306. Midshipman Non-Commissioned Officers (NCOs)

a. Appointment. Midshipman NCOs, except the Company Master Chief Petty Officer (MCMC), Platoon Sergeant (PLTSGT) and Color Guard Petty Officer (CGPTO), are appointed by and serve at the pleasure of the Company Commander with the approval of the Unit CO. Normally, only the MCMC, PLTSGT, and CGPTO will be assigned as MIDN NCOs. The Unit staff may designate more billets to be filled by MIDN NCOs as needed.

b. Criteria. Midshipmen selected must exemplify the personal characteristics sought in future Naval and Marine Corps Officers.

c. Midshipman Non-Commissioned Officer Ranks. Midshipmen NCO ranks for the corresponding billets are as follows:

<u>NCO Assignment</u>	<u>Navy Option</u>	<u>Midshipman Rank</u>	<u>Marine Option</u>
Company MCMC	Master Chief Petty Officer		Sergeant Major
Platoon Sergeant	Chief Petty Officer		Gunnery Sergeant
Squad Leader	Petty Officer First Class		Staff Sergeant
Color Guard/Pistol/Sailing Team	Petty Officer First Class		Staff Sergeant

d. Non-Commissioned Officer Billet Description

(1) Company Master Chief Petty Officer (MCMC). The MCMC will act towards the unit as a senior enlisted advisor would in the fleet.

(a) Responsibilities. The MCMC forms the Company during drills, passes word, and creates daily muster reports for the MOI and weekly reports

for the MCO. The MCMC works closely with the MCO to keep him or her informed on the state of the Company.

(b) The MCMC reports directly to the MCO.

(2) Platoon Sergeant (PLTSGT). The PLTSGT is responsible for mustering the Platoon and passing word to students in the Platoon ranks.

(a) The PLTSGT reports directly to the PLTCO.

(3) Squad Leader (SQDLDR). The Platoon will consist of at least three Squads, and more if the Unit staff deems necessary.

(a) Squad Leaders will develop Midshipmen in their squads through instruction and personal example. They will effectively carry out the missions assigned to them using members of the squad as a team. They are responsible for assigning and training the Fire Team Leaders (FTLDRs) in their Squad.

(b) The Squad Leader reports directly to the Platoon Sergeant.

(4) Color Guard Petty Officer (CGPTO). The CGPTO is appointed by the MCO as deemed necessary by the Unit Staff.

(a) Responsibilities. The Drill/Color Guard Petty Officer's primary responsibility is to assemble, train, and maintain a color guard to represent the Unit at competitions, selected events and social functions.

(b) The CGPTO reports directly to the MCMC concerning Color Guard details and events. He or she is assigned to a squad and reports to his or her Squad Leader concerning all other matters. The CGPTO will also work extensively with the AMOI to further the Guard's training.

Figure 3-1: Nominal Unit Organization

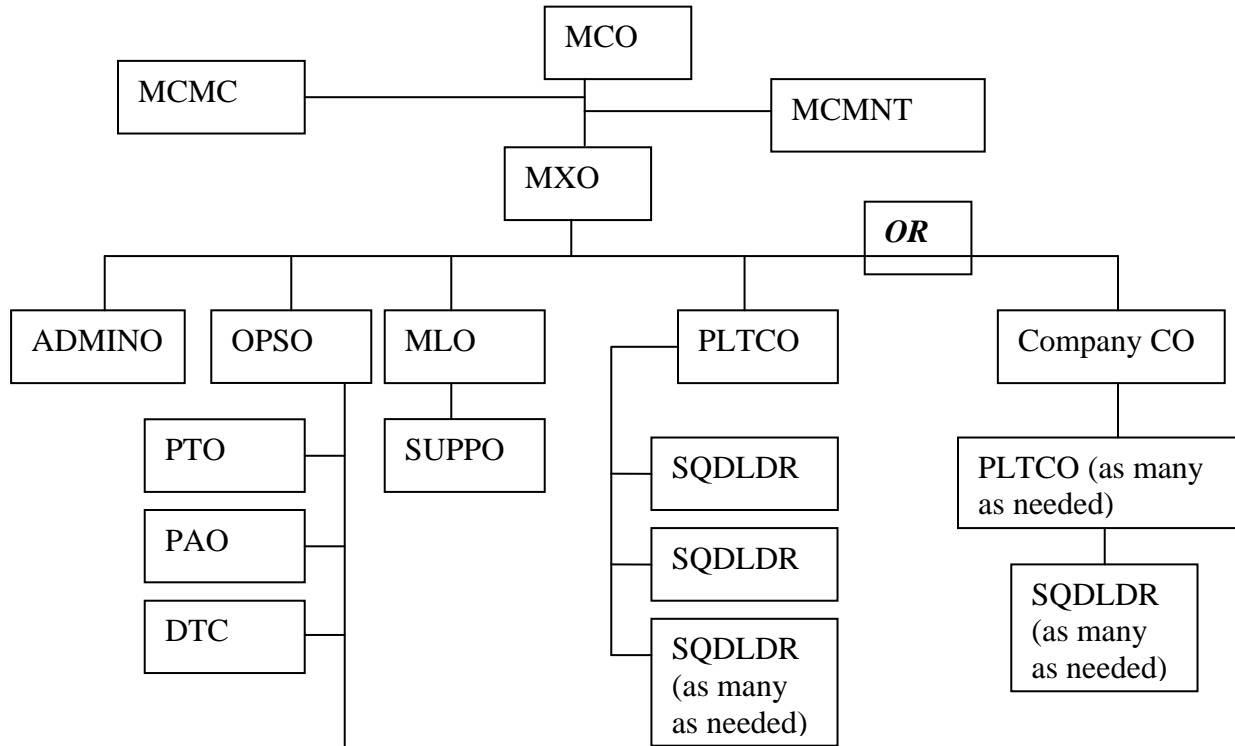

NOTE: The arrangement of the Midshipmen ranks is at the discretion of the Professional Staff and may be changed as needed based on unit size. However, the hierarchy in the fleet is as follows: Company, Platoon, Squad, Fire Team.

CHAPTER 4
PHYSICAL FITNESS

401. General. The Navy and Marine Corps emphasize physical fitness as a lifestyle for their officers. The physical conditioning aspects of the NROTC Program are designed to increase endurance and strength capability. Midshipmen are expected to meet Navy or Marine Corps fitness standards, as appropriate, and are encouraged to seek the advice of university physical education instructors, the Assistant Marine Officer Instructor, or the Command Fitness Leader (CFL) to assist in establishing a fitness program.

a. Incentive based Physical Training Program. (Tier Program) A tier based physical training program is established to motivate students to create and maintain a fitness lifestyle. Students will be assigned to 1 of 3 tiers based on results of the beginning of the semester inventory and mid-semester Physical Fitness Test/Physical Fitness Assessment.

TIERS

1. Tier I - Pass Height/Weight standards, score Excellent Low or better on the PFA, or 265 or better on the PFT.
2. Tier II - Pass Height/Weight standards, score between Good High and Good Low overall on the PFA, or score less than 264 but more than 225 on the PFT.
3. Tier III - Fails Height/Weight, fails any portion of the PFA or scores below Good Low overall on the PFA, or score below 225 on the PFT.

INCENTIVE

b. Tier Assignments. At the beginning of each semester, based on the results of the inventory PFA/PFT, students will be assigned to a tier as described above. Students assigned to Tier I are only required to attend all-hands PT events: All PFAs/PFTs and Company Runs. Tier II students are required to attend all hands PT events and mandatory PT (Wednesdays each week at 0530). Tier III students are required to attend remedial PT (Monday and Friday each week at 0530) and mandatory PT each week. A mock PRT/PFT will be held at mid-semester to allow students to move from Tier to Tier. Swimming is scheduled for every first and third Wednesdays and will be attended by all Midshipmen regardless of Tier assignment. Students who achieve second class swim qualification at the beginning of the semester will be excused from scheduled swim events for the remainder of the semester.

c. Testing. Each student is required to pass the Navy Physical Fitness Assessment (PFA) or Marine Corps Physical Fitness Test (PFT) each semester. Midshipmen will have only one opportunity per semester to take the official PFA/PFT. Failures of any kind will be adjudicated in accordance with the Regulations for Officer Development (ROD) and OPNAVINST 6110.1G (series).

d. The Navy Physical Fitness Assessment (PFA)

(1) PFA Events. The PFA is composed of two components: the Body Composition Assessment (BCA) and Physical Readiness Test (PRT). The PRT is composed of two minutes of sit-ups, two minutes of push-ups, and a 1.5 mile run. The BCA evaluates whether or not a student is within body weight standards for their height. If a student exceeds their weight limit, he/she will be tape measured to determine his/her body fat percentage. See the Command Fitness Leader or PTO to determine your allowed weight.

The Navy's maximum allowed percentage of body fat for males is 22% and for females is 33%.

(2) PRT Scoring and Standards. Individuals will be given a score for each event of the PRT based upon their performance. The average of these three scores will be the individual's overall score. The student must achieve the "Satisfactory Medium" requirement listed for each event of the PRT. Failure to pass any component will constitute a failure of the entire PFA.

d. The Marine Corps Physical Fitness Test (PFT)

(1) PFT Events. The PFT is composed of 4 individual components: the Body Composition Assessment (BCA), two minutes of sit-ups, max number of pull-ups or timed flex-arm hang, and a 3 mile run. To pass the PFT, members must be within body weight standards for their height. If an individual exceeds their weight limit, they will be tape measured to determine body fat percentage. Then the member must achieve the minimum requirement for each event of the PFT plus a minimum overall score. Failure to pass any component will constitute a failure of the entire PFT. See the Assistant Marine Officer Instructor (AMOI) for height and weight standards and minimum required performance in each category.

(2) PFT Scoring and Standards. Each student must achieve the minimum score for each event and earn a minimum total score to pass. Students must be aware that the minimum acceptable standards for each event together will not result in a passing total score. Failure to attain the minimum score in any single event constitutes failure of the entire PFA/PFT regardless of the total number of points earned. The Marine Corps' maximum allowed percentage of body fat for males is 18% and for females is 26%. Designated monitors will record each student's score for each event of the PFA/PFT. The Midshipman Physical Training Officer (MPTO) with assistance from the Command Fitness Leader, usually the AMOI, will compute each student's total PFA/PFT score.

(3) PFA/PFT Performance Recognition. Midshipmen who are within height and weight standards and score an overall "Outstanding" with no less than "Good Low" in each event on the official PFA or score 285 points or better on an official PFT will be awarded a Physical Fitness **Excellence** Certificate. Other forms of recognition may be available for Midshipmen who score 300 points. Midshipmen who are within height and weight standards and score an overall "Excellence" with no less than "Good Low" in each event on the official PFA or score 265 points or better on an official PFT will be awarded a Physical Fitness **Achievement** Certificate. The Midshipman Physical Training Officer will provide the Midshipman Administrative Officer with the requisite scores and a list of students who merit Physical Fitness Excellence and Achievement Certificates by the end of the semester. The Midshipman Administrative Officer shall prepare the required certificates and route them up the chain of command to the Commanding Officer in time for presentation at the first drill of the new semester.

e. Weight Control. Students who fail a BCA shall be assigned to the command's Fitness Enhancement Program (FEP) for 2 semesters. Students will not be commissioned, or eligible for scholarship contention, until BCA standards are met. FEP students are considered to be on Tier 3 as long as they are assigned to FEP, and shall work closely with the PTO, AMOI, and CFL to efficiently and safely bring themselves within standards.

f. Swimming. Swim tests are given to NROTC students each semester. The Navy's 3rd Class Swim Test consists of a high jump, 50 meter swim, prone float, and trouser inflate. Students must pass this test yearly in order to remain on scholarship and be commissioned. The Navy's 2nd Class Swim Test is available for interested students to take. See your advisor for details.

g. Commissioning Guidance. In addition to the standards presented above, all Navy Option Midshipmen and OCs must achieve a 'Good Low' or better overall during their senior year. Failure to do so will result in the student not being commissioned. All Marine Option Midshipmen and MECEP students must attain a First Class overall score during their senior year. See your advisor for details.

h. Failure to Pass PFA/PFT, Third Class Swim, or Height/Weight Standards. Failure of the physical fitness assessment, physical fitness test or third class swim qualification will result in a documented counseling by the Unit staff and will be further adjudicated in accordance with the Regulations for Officer Development (ROD). Additional failure may result in the student being placed on Probation or Leave of Absence (or scholarship suspension) or Disenrollment. See your advisor for details.

402. Fitness Standards, Guidance, and Responsibilities

a. Navy Standards. The Height/Weight standards, PFA scoring tables, and scoring procedures are published in OPNAVINST 6110.1 (series).

b. Marine Corps Standards. The Height/Weight standards, PFT scoring tables, and scoring procedures are published in Marine Corps Order (MCO) P6100.12.

c. Guidance. The MOI, AMOI, and CFL are trained in the above mentioned instructions and are available to assist any student in obtaining information from them, as well as answering any questions regarding fitness activity.

d. Student Responsibilities. Each student is responsible for knowing their allowed weight for their height, the standards required by their age group and gender to pass the PRT/PFT, and for developing a mindset of physical fitness to become part of their lifestyle as an officer-in-training.

CHAPTER 5
MIDSHIPMAN ACADEMICS

501. General. NROTC students may choose any degree program offered by their host university, subject to approval by the PNS. Majors in the science and engineering fields are encouraged, and changes to a student's major must not take place without PNS approval. In addition to completing University degree requirements, a student must complete certain courses required by the NROTC program in addition to those needed for their degree in order to be commissioned. Consult your University advisor with any question regarding academics, degree requirements, or majors.

502. Academic Majors. Responsibility for selecting and applying for a major rests with the midshipman and should be completed prior to the end of the first year. Since the choice of major, as well as a change in major, may affect a Midshipman's graduation date and status in the program, midshipmen deciding on a major or contemplating a change in major, must consult with their NROTC advisor. While all University students consult with a University advisor for help in determining a major program, midshipmen should also seek assistance from members of the NYGA in order to ensure that additional NROTC academic requirements are met.

503. Curriculum Requirements:

a. Midshipmen are required to take the Naval Science courses appropriate for their year group. Note that not all credits for Naval Science courses may be applicable for graduation credit requirements. Check with your University advisor.

b. Midshipmen must take the Naval Science Laboratory during every semester they are enrolled in the Program. A minimum of eight semesters of Leadership Laboratory are required to successfully complete the Four Year NROTC Program. If no other alternative exists, midshipmen may be excused from the Leadership Laboratory for the semester due to a class conflict with a required class. Only the Professor of Naval Science can grant such permission.

c. NROTC Course Requirements

(1) Each student is required to consult with their Advisor prior to registering for classes to ensure that they enroll in the required Naval Science and academic courses in order to ensure that all graduation and commissioning requirements are met in a timely manner.

(2) The Naval Science Institute (NSI) fulfills the course requirements for first- and second-year classes for 2-Year Scholarship Midshipmen and OCs.

(3) Navy College Program students should complete the scholarship course requirements as early in their academic programs as possible in order to be competitive for scholarship contention.

(4) All NROTC required classes must be taken on a letter grade basis. All classes taken at universities other than the host school must be transferable in both credit hours and letter grade.

d. Advanced/Transfer Credit. Courses completed at other than SSU or AASU must be transferable for credit to the student's university before they can be used to satisfy curriculum requirements. Students who have taken a calculus or calculus-based physics course for college credit in high school, which the University has validated, must complete one additional course at an approved university. Students are strongly encouraged to complete the University courses to improve foundations in these subjects even if they have validated credit from high school. Advanced placement credit does not validate any other curriculum requirements. Consult your NYGA for details or questions.

504. Academic Workload and Dropping Courses. It is the student's responsibility to take appropriate and sufficient courses each semester to make satisfactory progress toward graduation. Students will be expected to enroll in at least 15 but no more than 18 credit hours per semester. Exceptions to this must be approved by the Advisor. Students must consult with their NYGA advisor prior to dropping any course during the semester. Students who withdraw from courses without authorization or who fall below 12 hours of coursework during the semester will be placed on Leave of Absence, unless approved by the Professor of Naval Science in advance.

505. Attendance Policy

a. University Classes. Class attendance is essential to a student's academic success, since attendance and participation often are graded parts of university courses. Class attendance is also a measure of self-discipline and aptitude for commissioned service. A student who receives poor grades because of unauthorized absences in any class may be subject to further disciplinary action by the unit. Students are expected to attend all classes. Absences from any class must be approved by the advisor in advance. Consult your advisor for guidance regarding emergencies.

b. Naval Science Courses. Students are expected to attend Naval Science classes without exception. Consult the staff member teaching a particular class for policy regarding absences. Students with an excessive number of unauthorized absences from Naval Science classes may receive a failing grade, poor marks on evaluations, or be subject to disciplinary action by the unit.

c. Naval Science Leadership Laboratory

(1) Naval Leadership Laboratory is a Naval Science course. Therefore, students must attend unless given prior authorization by the MOI.

(2) Authorization for unavoidable absence must be obtained in advance from the MOI via the midshipman's chain of command if time permits. Consult the MOI for policy regarding emergencies.

(3) A Midshipman who desires to take an academic course offered only during Leadership Laboratory must submit a special request chit through the chain of command (including the Year Group Advisor) to the Professor of Naval Science. Approval by the PNS must be obtained before the student is allowed to register for any courses. If approved, documentation to that effect will be entered into the Midshipman's performance record and participation in Leadership Laboratory that semester will be waived. Attendance at an Alternate Lab session will be required. Every effort must be made to arrange the midshipman's academic schedule so that such conflicts do not arise.

506. Classroom Conduct. Midshipmen are expected to conduct themselves as professionals and Naval Officers in Naval Science classes. Basic requirements for standards of student conduct in the classroom are contained in Article 601. The Naval Science Instructors will promulgate specific requirements pertaining to how each course will be conducted in their course syllabus. It is the responsibility of each student to know and execute the basic and specific policies for classroom conduct at all times.

507. Grades

a. Good Academic Performance is Mandatory. Students are expected to work to their full academic potential. All students should strive to do their best and are strongly encouraged to achieve at least a 3.0 GPA each semester. Although not mandatory, it has been shown that GPAs in excess of 3.0 have greatly enhanced a student's service selection chances and given College Program students a much better chance of earning a scholarship. The minimum GPA required for each semester is set forth in the ROD and is: 2.5 for Navy and Marine Option Midshipmen, MECEPS, and OCs; 2.0 for Nurse Option Midshipmen; and 3.0 for STA-21(N) OCs. Failure of any required class, or failure to achieve the minimum GPA each term will result in students being assigned to the Mandatory Study Program (MSP) and may be subject to disciplinary action by the unit. Academic excellence is important for several reasons:

(1) The engineering and weapons systems on current and future ships and aircraft are complex and will require the best educated and trained officers to employ them.

(2) Grades are the major determining factor for the first duty assignment for newly commissioned Naval Officers. An outstanding academic record will enable an officer to qualify for the best and most challenging assignments throughout a career. This includes not only warfare assignments but postgraduate education and service college assignments as well. For future Naval Officers, relative seniority in a rank, represented by an individual's lineal number, is determined by a formula in which University course grades count 60 percent, and Naval Science grades and military aptitude marks count 20 percent each.

(3) Grades also play a major factor in selecting which College Program Midshipmen should be considered for scholarship contention.

508. Academic Warning, Probation and Leave of Absence.

a. Academic Warning. A student may be placed on Academic Warning for failing to achieve their required minimum term GPA, as long as no failing grades were received. Students on Academic Warning shall participate in the command's Mandatory Study Program.

b. Academic Probation. A student will be placed on Academic Probation if they fail any required course, if their term GPA is less than 2.0, or if their cumulative GPA drops below 2.0. Students on Academic Probation shall participate in the command's Mandatory Study Program.

c. Academic Leave of Absence (LOA). Leave of Absence is a suspension of scholarship benefits for no less than one semester. Students who are on Probation and fail to achieve satisfactory academic performance in the following semester, students who fail to complete calculus and physics completion time requirements, and students who withdraw from courses without

prior approval or who drop below 12 hours of enrollment during a semester shall be placed on LOA.

d. Good Standing. A student is said to be in good standing academically if they achieve the minimum required GPA with no failing grades in a semester. If the student was on Warning, Probation, or LOA in a semester, they must achieve the minimum required GPA with no failing grades in that semester in order to regain good standing. Failure to regain good standing while under academic action will result in further academic action, including LOA and possibly disenrollment.

509. Mandatory Study Program. Students placed on Academic Warning or Academic Probation shall participate in the command's Mandatory Study Program for the following semester. The Mandatory Study Program consists of required study hours as prescribed by the Unit's MSP, meetings with advisors no less than once each week to monitor progress, and additional training as deemed necessary by the professional staff. The Mandatory Study Program is conducted by the Unit's Academics Officer. Program guidance is contained in NROTCUINST 1533.5 (series). It is the responsibility of each student on Mandatory Study to abide by this instruction fully and notify the Academics Officer if full compliance is not possible. Failure to abide by the Mandatory Study Program will result in academic or disciplinary action.

CHAPTER 6
CONDUCT AND PERFORMANCE

601. Standards of Conduct

a. Purpose. The standards of conduct, which Officers are expected to observe, derive from both custom and legislation. The standards that have been enacted into law are intended to prevent use of public office for personal gain. Standards of conduct which are handed down by custom are necessary to promote harmony and good order during peacetime and to ensure victory in time of war. Adherence to naval customs involves development of the virtues of honor, courage, commitment, personal integrity, dedication to duty, and loyalty. Development of these virtues is not confined to four years of college, but instead is a lifetime process. A goal of the NROTC program is for each midshipman to recognize and adhere to all standards of conduct for Naval Officers.

b. Basic Customs. Some of the customs of the Naval Service which promote military virtues are as follows:

(1) Saluting and Greeting. The salute is a long established form of greeting and recognition exchanged between members of the military profession. Students in uniform shall salute commissioned officers of all branches of the Armed Forces, whether or not the senior is in uniform. Salute only when outdoors and covered. A time of day greeting is always in order regardless of cover. It is customary to exchange a greeting with the salute such as "Good morning, sir", "Good afternoon, ma'am", or "Good evening, LT___", if the person is recognized. If two or more officers in a group are met, make your greeting to the senior officer. If there are two or more officers of the senior rank and of the same sex, address them as "gentlemen" or "ladies."

(2) Addressing Officers. Students shall stand at attention when addressing or being addressed by an officer. Officers of all military services are addressed by their rank with the following exceptions. Officers of the Medical and Dental Corps may be addressed as "Doctor." Officers of the Chaplain Corps may be addressed as "Chaplain." When addressing an officer whose rank includes a modifier, the modifier may be dropped, e.g., Lieutenants (junior grade) may be addressed as Lieutenant. When in doubt, use 'Sir' or 'Ma'am', as these are always appropriate addresses.

(3) Courtesy and Deference to Military Seniors. In the Naval Services, courtesy and deference to military seniors is strictly observed. For example: Juniors give way to seniors; juniors walk to the left and slightly to the rear of seniors when in company; juniors do not interrupt seniors except in emergencies. All orders received by students from Unit personnel or midshipman officers shall be considered official and executed accordingly. Expressed wishes or desires of a military senior, by tradition, are tantamount to an order to a junior.

(4) Entering an Officer's Office. When a midshipman wishes to enter a commissioned officer's office, or any unit staff office space, the following procedure will be observed:

(a) If the officer(s) or staff is occupied, do not interrupt.

(b) When ready to enter knock three times, center yourself in the doorway, and speak: "Midshipman (1st/2nd/3rd/4th) Class (or Officer Candidate) (or Marine Rank) (Last name), Request Permission to Enter."

(c) Once given permission to enter by a staff member, enter the space and proceed swiftly to the place you need to go. Stand at attention in front of the staff member you intend to speak to and state your business.

(d) Remain standing and at attention until directed otherwise by the staff member.

(e) When dismissed, stand (if seated), face about and march out.

(5) Classroom Procedure. Military courtesy extends to the Naval Science classroom. When the instructor enters the classroom, a designated student will call the class to attention. Students will remain standing until the instructor gives the order to be seated. Students who are late for class will quietly take the nearest vacant seat, and will explain their tardiness to the instructor immediately after class.

(6) Smoking. Midshipmen will not smoke, in McGlockton Building, in any Navy vehicle, or at any Navy or Joint Service function.

(7) Conversing with Officers and Staff Members. The words "Sir" and "Ma'am" are military expressions that shall always be used in conversations with officers. The Five Basic Responses, which all students shall learn to use, are:

(a) "Yes, Sir" or "Yes, Ma'am".

(b) "No, Sir" or "No, Ma'am".

(c) "Aye Aye, Sir" or "Aye Aye, Ma'am". Used when responding to an order. It means, "I have heard the order, I understand the order, and I will carry out the order."

(d) "No Excuse, Sir" or "No Excuse, Ma'am". Used for when you would want to make an excuse for questioned behavior.

(e) "I'll Find Out, Sir" or "I'll Find Out, Ma'am". Used when you don't know the answer to the question you're being asked.

(8) Standards of Etiquette. While etiquette is not a matter of Navy Regulations, it must be recognized that an officer is judged not only by his professional ability, but also by his manners in his social and official life. An officer is expected to exercise tact and to possess social poise. Students should avail themselves of every opportunity to learn, through reading and observation, those aspects of gentlemanly or ladylike conduct that will be expected of them as officers. These include procedures at social gatherings and official functions. Accordingly, certain social events are conducted during the year that should be mandatory. In all social contact, midshipmen shall conduct themselves in keeping with good judgment and common sense.

(9) Standards of Dress. Students shall maintain high standards of personal appearance both while in uniform and in civilian attire. Students must remember that they are representing the United States Navy and Marine Corps, in uniform and out, in dealings with professors and administrators, with local merchants and townspeople, with civilian classmates, and with members of the Company. Refer to Chapter 9 for a complete listing of regulations regarding uniforms, civilian attire, and grooming standards.

Students shall not report to the unit unless they are within dress standards.

602. Aptitude Evaluation

a. Introduction. The NROTC military performance system is designed to determine a midshipman's suitability for commissioned Naval Service. Scholarship and College Program students are evaluated throughout their education. Report forms are used on a program-wide basis, and performance marks are based upon evaluation by the midshipman chain of command and Unit Staff. Performance reports are used for the following:

(1) To provide assessment of individual aptitude of NROTC students with respect to Naval Officer standards.

(2) To identify NROTC students who possess exceptional qualities and potential.

(3) To identify NROTC students who have demonstrated weaknesses in officer-like qualities and potential, thus providing a sound basis for counseling and remedial efforts.

(4) To give each midshipman experience in observing and evaluating subordinates in a military environment using a format similar to the enlisted evaluation.

(5) To provide data that will be used to assist in the computation of lineal standing of NROTC graduates.

b. Aptitude Assessment Periods. An aptitude assessment is conducted at the completion of each semester for which the student is actively enrolled in the NROTC Program. These assessments are used to determine a midshipman's final aptitude average that is a component of the final class standing. Recognizing the importance of performance feedback, abbreviated mid-term evaluations shall also be conducted for the purpose of informing midshipmen of their level and trend of performance.

c. Performance Assessment Areas. The Evaluation Report & Counseling Record, NAVPERS 1610/2 (Appendix A), indicates the areas in which a midshipman's aptitude is assessed.

d. Procedure

(1) The evaluator will fill out the NAVFIT Fitness Report and Counseling Record using the block by block instructions listed in paragraph e. below. Table 6-1 lists specific primary and secondary evaluators. The primary evaluator fills out the Evaluation Report first and forwards it to the secondary evaluator (reporting senior) for his/her review and comments. .

(2) The Company Commanding Officer shall conduct a final review of all performance reports to ensure completeness and consistency, prior to forwarding them to the Advisors. Evaluation Report due dates will be promulgated by the Professional Staff and will usually coincide with the end of the academic semester. Performance counseling and evaluations should be completed by the students with this deadline in mind.

(3) The Advisors shall complete block 25 (performance comments) when the University makes semester grade point averages available. The completed reports with the computed final aptitude grade will be forwarded to the Unit Executive Officer and

Commanding Officer for final review. After approval by the CO, the Evaluation is filed in the student's Performance File to be read and signed by the student at the start of the next semester.

e. Block-by-Block Instructions. Note that in blocks with groups of three entry boxes, the left box is to be used for the first evaluator in the chain of command, the middle box by the second evaluator, and the right box by the Advisor. The solitary box above the three is used for midterm marks.

- Blocks 1-9: Self-explanatory.
- Block 10: Enter billet(s) held and major.
- Block 11: Enter all honors/awards received from the University or Company during the reporting period.
- Blocks 12-14: **Mid-term Counseling**- Enter the date mid-term counseling took place in block 12, the individual conducting the counseling in block 13, and the individual who was counseled should sign in block 14.
- Blocks 15-21: **Performance Traits** - General Instructions - For each trait, mark an "x" in the appropriate category. The primary grader will put their "x" in the left box, the secondary grader places their "x" in the middle box, and the Advisor places an "x" in the right-hand box. A mark of 3.0 means that a midshipman is meeting the standards (and those standards are high) and is not meant to connote substandard performance in any way. Midshipmen who are above or greatly exceed standards in certain performance traits should be noted. Likewise, below standard performance or unsatisfactory performance should be marked as necessary.
- Block 22: **Billet Recommendation** - Enter two billet recommendations.
- Blocks 23-25: **Comments**. Enter appropriate comments to support the marks in the performance report. Type your name at the bottom of your comments. Comments should include specifics regarding any individual strengths and weaknesses, awards received, special achievements accomplished during the semester, or any mast cases. Specific comments may be done in "bullet" fashion (partial sentences and phrases are permitted). Terms such as "none" should be avoided. Sign and date over your typed name and billet. Be careful to check spelling and grammar.
- Block 26: **Midshipman ranking** - The Advisor will place an "x" in the box that correctly reflects the midshipman's ranking. Top tier, second tier, and middle tier are positive ranking recommendations. Fourth tier means the midshipman is making progress but is not ready to be ranked higher. Bottom tier means the midshipman has serious shortcomings that must be justified in the comments section. A top limit of 20% of each class (rounded to nearest whole number) may be "top tier". A top limit of 40% of each class may be top tier and second tier.
- Block 27: **Signature of MCO**. Date must be actual signature date of the report.
- Block 28: **Signature of Midshipman evaluated** - This certifies the midshipman has reviewed the report. If a statement is desired, the block should be checked and a statement attached to the report.

Table 6-1: Primary and Secondary Evaluators by Billet

1. Students in ranks do not evaluate other Midshipmen. They are evaluated by (1) their SQDLDR and (2) the PLTCDR.
2. SQDLDRs evaluate all students in their squad. They are evaluated by (1) PLTCDR and (2) MXO.
3. The PLTCDR evaluates SQDLDRs and reviews for students in ranks. They are evaluated by (1) MXO and (2) MCO.
4. Student NCOs are evaluated by (1) PLTSGT and (2) MCMC.
5. The PLTSGT evaluates all NCOs in the PLT. They are evaluated by (1) MCMC and (2) MXO.
6. The MCMC evaluates all NCOs and is evaluated by (1) MCO.
7. The PAO evaluates nobody. They are evaluated by (1) MXO and (2) MCO.
8. The PTO evaluates nobody. They are evaluated by (1) OPSO and (2) MCO.
9. The OPSO evaluates the PTO. They are evaluated by (1) MXO and (2) MCO.
10. The SUPPO, MCMNT, and ADMINO evaluate nobody. They are evaluated by (1) MXO and (2) MCO.
11. The MXO evaluates the, PLTCDR, PAO, OPSO, SUPPO, MCMNT, and ADMINO and reviews for the SQDLDRs, PLTSGT.
12. The MCO evaluates the MCMC and MXO and reviews for PLTCDR, PAO, PTO, OPSO, SUPPO, MCMNT, and ADMINO.

NOTE: The table shown above is notional. Evaluation requirements may change with unit size. The MOI will promulgate evaluation requirements each semester. Consult the MOI to confirm this arrangement or for changes each semester.

f. Mid-term Counseling Instructions.

(1) The Evaluation Report & Counseling Record will be used for mid-term counseling of midshipmen by the end of the sixth week of each semester. Counseling should be a frank and open discussion of individual performance. The primary grader personally counsels each midshipman that he/she will evaluate using Table 6-1 as a guide. The Evaluation Report & Counseling Record contains blocks used for mid-term counseling. The primary grader marks an "x" in the mid-term block under each performance trait and ensures blocks 12-14 are completed to document the counseling. The comments section (block 23) will also be filled out mid-term to cite individual strengths and weaknesses in "bullet" format.

(2) Mid-term Counseling Records are working papers kept by the primary grader. At the end of the semester when writing the final evaluation, the grader will transcribe blocks 12 and 13 from the counseling record to the new Evaluation Report and have the evaluated Midshipman sign blocks 14 and 28. Mid-term grades are not transcribed to the Evaluation Report.

(3) The Company Commanding Officer is responsible for ensuring his/her chain of command performs and documents the mid-term counseling prior to the seventh week of each semester.

g. Aptitude Follow-up. The military performance system contains many areas of subjectivity. Therefore, aptitude evaluations must be carefully analyzed, whether for purposes of praise or censure. It is important that persons making aptitude evaluations be as objective as possible.

h. Counseling. Midshipmen will receive periodic counseling concerning their officer aptitude and will review and initial all performance reports.

Review is normally accomplished within the first 2 weeks of the academic term following aptitude grading. Graduating Midshipmen are to review their final performance reports during pre-commissioning counseling. Students having marginal performance grades will receive regular counseling and other supervision to help them improve.

603. Guidance and Counseling

a. Military and Naval Science Matters. Midshipmen are encouraged to seek advice and counsel from the members of the NROTC Staff. For guidance on matters pertaining to Naval Science, the student should consult with his Advisor. For matters of military nature, he should consult with his Advisor, a midshipman within the Company, or any Professional Staff member.

b. Other Matters. To discuss academic matters, questions of outside employment, financial problems, or other personal items the student should seek help from his Advisor. Students will be formally counseled at a minimum of three times per semester: initial, midterm, finals. Members of the staff do not maintain restricted office hours and are always available to counsel students. A student should not be afraid to seek advice from any Professional Staff member on any matter.

604. Performance Review Board

a. General. A Performance Review Board (PRB) may be convened to review a student's academic and/or aptitude record. Midshipmen concerned have the right to appear before such boards.

b. Composition. A PRB will consist of the Unit Executive Officer and at least two additional members (Advisors, MOI, University Representative), and the student's Advisor (non-voting).

c. Convening a PRB. A PRB will be convened in the following situations:

(1) Any deficiency requiring that the student be placed on LOA.

(2) Any disciplinary problem that is determined by the PNS to require such a level of investigation and resolution.

d. Outcomes of a PRB. The Board will recommend one of the following actions to the PNS, who will make the final determination:

(1) No action

(2) Letter of Warning

(3) Academic Probation

(4) Leave of Absence (LOA)

(5) Disenrollment from program

e. Actions. Personnel placed on Warning, Probation or LOA for either Academics or Aptitude will be notified in writing by the Commanding Officer. The notification will state the cause, period, and terms of the action. Failure to meet these terms can result in further action or disenrollment.

f. Participation by Students on LOA. Students on LOA shall participate in unit activities as directed by the PNS.

605. Summer Training

a. Requirement. Summer Training evaluations are performed by the command to which the midshipman is attached during summer training. In most cases, this evaluation is optional and commands do not perform midshipman evaluations. Some summer training commands, however, require such evaluations on all students participating. Discretion for evaluation lies with the training command. Consult the Summer Cruise Coordinator for questions.

b. At-Sea Training. Midshipmen participating in at-sea summer training may be evaluated by their ship's personnel. Often, such evaluation is reserved only for deficient or exceptional performance, but the choice of evaluating a midshipman lies with the sea command regardless of a midshipman's performance. If a midshipman is evaluated during an at-sea cruise, they must report such evaluation to the Summer Cruise Coordinator and provide their advisor with a copy of the evaluation to be placed in their performance file.

c. CORTRAMID. Officers in charge of CORTRAMID may prepare evaluation reports for Midshipmen. As with at-sea training, this is at the discretion of the command. If evaluated, the midshipman must inform the Summer Cruise Coordinator and provide a copy of the evaluation to their advisor to be filed in their performance file.

d. Marine Corps Training of Midshipmen (BULLDOG). Marine Corps Option NROTC students are evaluated in the manner outlined in the BULLDOG NROTC Field Training Manual. Final cruise standings and aptitude marks are forwarded to the NROTC Unit and kept in the student's performance file. Consult the MOI for questions.

CHAPTER 7

AWARDS

701. General. Awards are designed to recognize exceptional performance in the areas of academics, physical fitness, military aptitude, leadership, and participation in selected events or activities. Awards are sponsored by the unit and by outside organizations.

702. Awards Boards

a. Unit Staff Awards Board. The Unit Staff Awards Board, comprised of the MOI and the Advisors, will convene before the first drill lab of each semester to select the previous semester's student of the semester (see para 705) and to nominate recipients for awards sponsored by outside organizations. These awards will be presented at a time and place deemed appropriate by the PNS, normally in the form of a formal awards ceremony such as Spring Review, but also individually as the PNS sees fit. **The advisor of the student nominated for a particular award shall be responsible for preparing and submitted the required nominations.**

b. Company Staff Awards Board. The Company Staff Awards Board, comprised of the OPSO, MCMC, PLTCDR, DTC, STC, PTO, CGCPO and PTCPO, will convene before the end of each semester to nominate recipients for unit-level awards for the semester (see para 704). The nominations will be consolidated and routed from the Midshipman chain of command via the active duty staff prior to the Commanding Officer. The MCO has the right to recommend changes to the list of nominees. Once approved and signed by the Commanding Officer, these awards will be presented at the first drill lab of each semester.









703. Wear





a. Ribbons will be worn only on uniforms for which they are prescribed and will be worn on the bar centered above (1/4" for Navy Midshipmen and 1/8" for Marine Option Midshipmen) the left breast pocket, arranged in order of precedence from the wearer's right to left. Subsequent awards are designated by the addition of a gold star to the ribbon. A silver star replaces five gold stars on the ribbon. A ribbon, once awarded, is worn throughout the time the midshipman is in the NROTC Unit. Ribbons will be worn with appropriate uniforms during leadership labs. NROTC ribbons may not be worn while on summer cruise. Midshipmen may wear active duty ribbons in lieu of NROTC ribbons. Mixing NROTC ribbons and fleet ribbons is not authorized. Consult your advisor for policy concerning the wear of NROTC awards to military installations.

b. Officer Candidates are not authorized to wear NROTC awards.

c. MECEP students are not authorized to wear NROTC awards.

704. Order of Precedence and Requirements.

Ribbon	Award
 <p>Leadership/ Company Commendation</p>	<p>Midshipman must demonstrate inspirational performance within the Company either for specific instances or over a period of time that best exemplifies those aspects of character, leadership, and moral fiber desired of superior midshipmen and future officers in the Navy and Marine Corps.</p> <p>Nominated by: Midn Awards Board Reviewed by: MOI, Advisors, XO Approved by: Commanding Officer</p>
 <p>Distinguished Achievement (Superstar)</p>	<p>Individual must meet criteria for the Academic Excellence award, Leadership Excellence award, and Physical Fitness Achievement award for the same semester. The ribbon is worn in conjunction with the ribbons associated with the listed criteria awards.</p> <p>Nominated by: MOI, Advisors Reviewed by: Executive Officer Approved by: Commanding Officer</p>
 <p>Academic Star</p>	<p>Individual must maintain a cumulative GPA of 3.25 or above without having a semester GPA less than 3.2 over the same two semesters.</p> <p>Nominated by: MOI, Advisors Reviewed by: Executive Officer Approved by: Commanding Officer</p>
 <p>Academic Excellence</p>	<p>Individual must have achieved a semester GPA of 3.2 or above during the previous semesters.</p> <p>Nominated by: MOI, Advisors Reviewed by: Executive Officer Approved by: Commanding Officer</p>
 <p>Academic Achievement</p>	<p>Individual must have achieved a semester GPA of 3.0 or above during the previous semesters. This award may not be awarded in conjunction with Academic Excellence award for any single semester.</p> <p>Nominated by: MOI, Advisors Reviewed by: Executive Officer Approved by: Commanding Officer</p>
 <p>Aptitude/ Leadership Excellence</p>	<p>Midshipman who achieves an average aptitude rating of 4.0 or greater the previous semester with no individual marks below 4.0.</p> <p>Nominated by: MOI, Advisors Reviewed by: Executive Officer Approved by: Commanding Officer</p>
 <p>Leadership Achievement</p>	<p>Midshipman who achieves an average military aptitude of 4.0 or greater the previous semester with no individual marks below 3.0.</p> <p>Nominated by: MOI, Advisors Reviewed by: Executive Officer Approved by: Commanding Officer</p>
 <p>Physical Fitness Excellence</p>	<p>Individual must be within body weight standards and meet criteria below for the previous semester: Navy - Must have an overall PRT score of Outstanding while not scoring below a Good Low on any portion of the test. Marine - Must score a 285 or above on PFT.</p> <p>Nominated by: MPTO Reviewed by: AMOI, MOI, XO Approved by: Commanding Officer</p>
 <p>Physical Fitness Achievement</p>	<p>Individual must be within body weight standards and meet criteria below for the previous semester: Navy - Must have an overall PFA score of Excellent Low or better. Marine - Must score a 265 or above on PFT. Not awarded in conjunction with Physical Fitness Excellence award.</p> <p>Nominated by: MPTO Reviewed by: AMOI, MOI, XO Approved by: Commanding Officer</p>

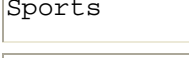
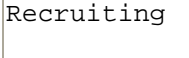
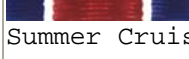
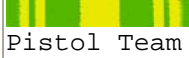
 Freshman Orientation Staff	<p>Individual must have been an active member of the Company Orientation Staff for the Fall semester's Freshmen Orientation.</p> <p>Nominated by: Midn Awards Board Reviewed by: MOI, Advisors, XO Approved by: Commanding Officer</p>
 Drill Team	<p>Worn by team members and any midshipmen that the Drill Team Commander sees fit to nominate for their service to the Drill Team (Gold frame for Commander).</p> <p>Nominated by: Midn Awards Board Reviewed by: MOI, Advisors, XO Approved by: Commanding Officer</p>
 Color Guard	<p>Participation on the Color Guard for the entire semester. (Gold frame for Commander).</p> <p>Nominated by: Midn Awards Board Reviewed by: MOI, Advisors, XO Approved by: Commanding Officer</p>
 Community Service	<p>Awarded to midshipmen who have shown a spirit of philanthropy by participating in a minimum of ten hours of Midshipman Company affiliated volunteer work for the semester.</p> <p>Nominated by: Midn Awards Board Reviewed by: MOI, Advisors, XO Approved by: Commanding Officer</p>
 Company/Collegiate Sports	<p>Awarded to the individual who has actively participated on a Company/Collegiate Sports Team whether varsity or intramural during the semester.</p> <p>Nominated by: Midn Awards Board Reviewed by: MOI, Advisors, XO Approved by: Commanding Officer</p>
 Recruiting	<p>Awarded to midshipmen who recruit one new student to the unit or who otherwise make a significant contribution to the Unit's recruiting effort as determined by the PNS.</p> <p>Nominated by: Midn Awards Board Reviewed by: MOI, Advisors, XO Approved by: Commanding Officer</p>
 Summer Cruise	<p>This award is presented to Midshipmen who participate in summer training.</p> <p>Nominated by: Midn Awards Board Reviewed by: MOI, Advisors, XO Approved by: Commanding Officer</p>
 Pistol Team	<p>This award is presented to Midshipmen who participate on the pistol team during the previous semester.</p> <p>Nominated by: Midn Awards Board Reviewed by: MOI, Advisors, XO Approved by: Commanding Officer</p>
 Sailing Team	<p>This award is presented to Midshipmen who participate on the sailing team during the previous semester. (Gold frame for Commander).</p> <p>Nominated by: Midn Awards Board Reviewed by: MOI, Advisors, XO Approved by: Commanding Officer</p>

705. Student of the Semester.

a. Description. This award is presented each semester for performance demonstrated in the previous semester to one student who epitomizes Midshipman all around superior performance by maintaining a high level of academic and military performance and involvement in Company and University activities. The Student of the Semester is so designated for the period of one semester and is also awarded the Company Commendation Ribbon.

(1) Criteria for Nomination. In order to qualify for nomination for student of the semester, student must:

- a. Passed the PFA/PFT and be within height and weight standards.
- b. Not been the subject of a Midshipman or Performance Review board during the semester being nominated.
- c. Cannot be on probation or in a leave of absence status.

(2) Selection Procedure. Prior to the beginning of each semester, each year group advisor will nominate one student from the Company as the student of the semester. A panel consisting of the Unit's Executive Officer, three advisors and the AMOI will sit on the board. The board will consider the following:

a. Semester GPA	3.76 - 4.00	12 points
	3.51 - 3.75	9 points
	3.26 - 3.50	6 points
	3.00 - 3.25	3 points
	2.75 - 2.99	1 Points
b. Semester GPA	3.76 - 4.00	12 points
	3.51 - 3.75	9 points
	3.26 - 3.50	6 points
	3.00 - 3.25	3 points
	2.75 - 2.99	1 Point
c. PFT/PFT Score	Tier I	8 points
	Tier II	5 points
	Tier III	3 Points
d. Swim Qualification	2 nd Class	5 points
	3 rd Class	3 points
e. Military Aptitude	3.51 - 4.00	5 points
	3.01 - 3.50	3 points
	2.50 - 3.00	1 point

(3) Award. The student selected as the Student of the Semester will earn the following:

- a. One month exclusion from any mandatory physical fitness (excluding PFT/PFA).
- b. The Company Commendation Ribbon.
- c. Photo taken and placed on the Student of the Semester Board.
- d. Notation of the student's evaluation or Fitness Report.
- e. Have the Commanding Officer present the award at the initial formation of the current semester.

f. Honorable mention certificates will be given to 2nd and 3rd place students.

b. Super Squad. Each semester one of the squads in the Company is recognized as the Super Squad - the best overall squad in the Company. The Company Commander and staff evaluate the performance of the squads in Operation Order performance, leadership, academics, drill competition, physical readiness, and uniform inspections and makes recommendations to the Professional Staff. The Super Squad is announced at the beginning of each semester for performance in the previous semester.

c. Other Awards. The Professional Staff may devise other means of recognition and associated NROTC ribbons. Consult your advisor with any questions regarding NROTC unit awards.

**CHAPTER 8
DISCIPLINE**

801. General

a. Students will conduct themselves as future officers throughout their military careers, starting with their training at this unit. Students shall not stray from the Core Values. Midshipmen are expected to be examples of self-discipline, honor, courage, and commitment. Because of the nature of their future job, Naval Service Officers must be ready to perform at their best at all times in all aspects of their life. This is to ensure that they can not only execute their own duties, but that they can also ensure the welfare of those for whom they have charge.

Remember: You are not an ordinary college student. You are a future military officer, and you must always act as such.

b. Each student is required to carry out the official orders of senior midshipman officers and petty officers when they are acting in their official capacity. Each student is also subordinate to their Advisor in all matters pertaining to the midshipman's obligation to the Naval Service. Any breach of conduct that would be detrimental to the morale and good name of the Company will be investigated. Such an offense will be evaluated and could lead to disciplinary action.

c. The purpose a discipline in Naval ROTC is not to punish. It is to correct deficiencies in a student's conduct. The means of correcting misconduct or deficiencies will not deviate from the sole purpose of rehabilitation of the individual. Any actions taken are aimed at creating a stronger, more focused midshipman.

At no time will any student award disciplinary action to another student without PNS permission. Disciplinary actions may be recommended by student staff, but can be authorized and carried out only with PNS permission!

(Consult your advisor with any questions regarding this matter.)

802. Offenses

a. Major Offenses. Major offenses are those which involve a serious breach of discipline, a hardened disregard or contempt for authority, an incorrigible lack of energy and purpose, a culpable lack of responsibility, a lack of moral courage, or which bring discredit upon the Naval Service. Offenses of these natures include, but are not limited to: fraud, theft, assault, plagiarism, willful disobedience of a lawful order, drug and alcohol abuse, and conduct unbecoming an officer. Midshipmen whose misconduct falls in one of these areas will be referred to the Professor of Naval Science for action and may be immediately dismissed from the program.

b. Minor Offenses. Minor offenses are of a less serious nature and generally involve infractions of Midshipmen Company rules and regulations such as tardiness or unexcused absences, improper uniform or haircut, or failure to carry out orders of senior midshipmen or professional staff. These offenses are normally handled using midshipmen Company counseling procedures. However, repeated minor offenses will result in a midshipman's appearance before a Company Review Board, akin to Captain's Review Board in the Navy. If the Company Commander feels it is necessary, he or she can recommend the deficient midshipman appear before a Unit Performance Review Board for inaptitude, which can lead to disenrollment from the NROTC Program.

803. Reporting Offenses

a. Absence Offenses: All students absent from or tardy to any mandatory event will be reported to the MCMC via the SQDLDR. Those students with unexcused absences will be formally counseled and referred to the appropriate personnel for action.

b. Offenses other than absence

(1) Any minor offense concerning a midshipman will be reported to that individual's chain of command.

(2) Alleged major offenses are to be referred directly to the Company Commander. The Company Commander will forward major offense reports to the Unit's Commanding Officer via the Advisors and the Executive Officer.

804. Handling of Offenses

a. Minor offenses are handled at the student level using the counseling procedures below. If the counselor feels the counseling is ineffective, he or she can refer it to the MCO. The MCO may either rule on the case in Company Review Board Procedures or recommend Unit Staff involvement, either through a Performance Review Board, or counseling at the Unit Staff level.

b. A Midshipman who feels that his Company Review Board or Extra Military Instruction was unjust or unfair may appeal in writing (within 72 hours) to the Unit Commanding Officer via the chain of command.

c. Offenses that would normally require action against active duty students will be handled directly by the Unit Staff.

805. Counseling

a. Counseling is an integral part of both mission accomplishment and unit welfare, and is often the first corrective action taken when an individual's actions are deficient. Rather than punishing, counseling serves the purpose of providing a forum for the senior to discuss deficiencies in the junior's actions and to recommend courses of action to correct these deficiencies. Likewise, a counseling session also provides the junior the opportunity to present their case to the senior. All counseling held for this purpose shall be documented on an appropriate form and forwarded to the appropriate BN staff members as well as that student's advisor.

b. The progression for the counseling of a student will follow the given chain of command. Students in Company staff positions will be counseled by their respective superiors. The form for documenting all such sessions is located at the end of this chapter. This form may be reproduced or modified as necessary.

(1) Squad leaders will address any minor deficiencies with an informal counseling session, to be conducted immediately and privately. Squad leaders must document all counseling sessions and maintain these counseling sheets for review upon request by unit staff or professional staff members.

(2) Platoon/Company Commanders shall record all counseling sessions that take place within their Platoon/Company and shall be provided counseling records by SQDLDRs upon request. They shall forward all counseling records to the MXO if the individual has prior counseling on the same offense.

(3) The MCMC shall conduct a final formal counseling session if needed. The MCMC shall be provided records of prior counseling by staff members and use this as part of the counseling. This counseling shall also be recorded and forwarded to the MCO and the student's advisor upon completion.

c. If counseling procedures prove ineffective in dealing with the deficiency, a Company Review Board (MCRB) may be conducted at the MCO's discretion or at the request of an advisor. A MCRB is intended as an investigative and corrective measure for seriously deficient midshipmen. If the deficient student is in their second, third, or fourth year, the MCMC may choose to counsel the student directly and forego counseling by the SQDLDR and PLTCO/CCO.

806. Conduct of Company Review Board

a. General. Company Review Boards are intended for use as a tool by the MCO to investigate, address, and correct any serious or repeated deficiency not requiring immediate professional staff involvement. Students brought before a MCRB shall be notified in writing 2 days in advance of the convening of the MCRB. This notification may be accomplished using a counseling sheet and must include what uniform the student is to wear. All personnel in attendance shall wear the prescribed seasonal uniform.

(1) The following personnel, at a minimum, shall attend the MCRB:

- (a) Student on report
- (b) Platoon/Company Commander
- (c) Company Commander
- (d) Company Executive Officer
- (e) Administrative Officer
- (f) Company MCMC
- (g) Witnesses, as appropriate

(2) The MCMC will present the student on report, who will then enter and state, "Midshipman _____, reporting to the Company Commanding Officer as ordered."

(3) The MCO will read the charges and present witnesses to support them. The student will then be given the opportunity to speak on his or her behalf and to present witnesses in his/her defense.

(4) Once the MCO has finished with the student, The MCMC will escort the student from the proceedings. The MCO will then determine the appropriate course of action for the student, seeking advice from the other staff members as the need arises. The MCO shall consider all factors in the case and may follow any of the following courses of action:

- (a) Dismiss the charges.
- (b) Recommend extra military instruction (EMI).
- (c) Refer the case to the Unit XO.

(5) The MCMC will escort the student back into the proceedings. The student will report as described above. The MCO will announce their decision and dismiss the student.

(6) MCRB proceedings and results must be documented carefully by the MCMC. A MCRB log will be maintained for this purpose and kept by the MCO.

(7) Results of MCRBs are summarized in a standard naval letter from the MCO to the Unit XO via the student's advisor. The letter must contain details of the proceedings, the names of those present, and the MCO's findings. The MCO may include additional material, such as counseling sheets, as deemed appropriate. MCRB results shall be placed in the student's Performance File.

If the MCO recommends EMI, that EMI cannot be awarded or carried out until the Professional Staff has approved it!

807. Extra Military Instruction (EMI)

a. Definition. Extra Military Instruction, or EMI, is a corrective action for all students to handle minor infractions without permanent record of that infraction. EMI is a management tool used by the chain of command to correct a shortcoming in a student's performance.

b. Purpose. The specific purpose of EMI is to engage the individual in an activity that will be corrective and meaningful, both to the individual and the command, in order to correct a shortcoming and prevent a future occurrence. At no time will EMI stray from this intent, nor will it be used in a manner that would constitute hazing, nor will it be used to humiliate the individual either in public or private.

c. Administration

(1) EMI can be recommended by any student staff member, but must be approved by the professional staff prior to the execution of EMI on another student. EMI can also be directly awarded by the professional staff.

(2) EMI shall be scheduled to not interfere with the student's class schedule, and shall not be performed on Sundays or legal holidays.

(3) EMI examples include, but are not limited to: additional uniform inspections, creating and giving presentations related to the individual's deficiency, preparing essays on the subject of the student's deficiency, extra musters, and required attendance at PT or drill sessions which the student may not normally be required to attend. A member of the Company staff shall monitor the execution of EMI and will report its completion to the appropriate personnel.

808. Uniform Code of Military Justice (UCMJ): During Summer Training, NROTC Midshipmen are on active duty and are therefore subject to the UCMJ. Commanding Officers of training units may assign disciplinary measures appropriate to the offense and, for serious offenses, may award punishment under the UCMJ. All such offenses will be reported to the Professor of Naval Science for review and appropriate action and documented in the student's Performance File.

809. Indebtedness: Students shall not, without specific approval from the Unit Commanding Officer or Executive Officer, obligate any organization or group within the Unit or enter into any financial transactions that could possibly result in indebtedness on the part of the Unit or any Navy sponsored activity. All students shall conduct their private financial transactions in such a manner that does not reflect discredit on them, the Unit, or the Naval Service. Consult your advisor prior to any major financial transaction for guidance.

CHAPTER 9
MIDSHIPMAN UNIFORMS

901. General

a. Uniform wear. NROTC students are required to wear uniforms on Naval Science Leadership Laboratory days and at other specified times. Students shall properly maintain all uniform items issued to them at all times.

b. Guidance. Uniforms worn by midshipmen match those worn by active duty Naval Officers as closely as practicable. Specific guidance on Midshipman uniforms can be found in United States Navy Uniform Regulations. **At no time shall guidance given here override that found in the Uniform Regulations. In the case of a conflict between the two, the Uniform Regulations shall take precedence.**

902. Uniform Issues

a. General. Upon entering the program, all midshipmen are provided the necessary uniforms and accessories. The Unit Supply Technician shall promulgate the list of items to be issued upon student entry. The individual midshipman is responsible for ensuring that he or she has all of the required items and that they are in good condition. Worn or outgrown items may be taken to the Unit Storekeeper for exchange. The decision to exchange or alter an item at unit expense lies with the unit Supply Technician. *Midshipmen must be prepared to pay for additional alterations and lost or damaged items.*

b. Summer Training Uniforms. In addition to basic uniform clothing, certain items are also provided in preparation for Summer Training. The Summer Cruise Coordinator will publish the list of required uniform items to each student based on the nature of their cruise. It is the student's responsibility to acquire and maintain these items in a timely matter. Certain uniform items may need to be returned to the Unit Supply Technician upon completion of Summer Training. While on Summer Training, midshipmen shall wear the rank insignia of the class of midshipman that they will become upon commencement of classes that fall. For example, a student completing their 4/C year shall wear 3/C insignia on their cruise. Additionally, midshipmen shall not wear any unit awards as shown in Chapter 7. Questions regarding Summer Training uniforms and requirements may be directed to the Summer Cruise Coordinator.

c. Name Tags. Each new midshipman will receive a nametag. Any additional nametags will be at the expense of the midshipman.

d. Items Not Issued. Certain items worn on a daily basis by students are not issued by the unit. These include, but are not limited to: Undergarments, swimwear, white t-shirts, running shoes, etc. These items must be acquired at student expense and are required for performance at the unit. Questions regarding what items are issued and what items you must purchase can be directed to either the Unit Supply Technician or your advisor.

903. Return of Uniforms

a. Upon disenrollment. All uniform items must be returned to the Unit Storekeeper clean and ready for reissue. Missing items or items damaged as a result of misuse will be replaced in kind. Consult the Unit Supply Technician for questions regarding this situation.

b. Upon Commissioning. Some uniform items that are issued must be returned to the Unit Supply Technician upon commissioning. The Unit Supply Technician will inform the commissionee what items must be returned. It is the responsibility of the student to return these items in a timely manner.

904. Alterations. The Unit may pay for certain alterations for uniforms that are issued by the Unit. Uniforms may be tailored to provide a well-fitting, professional military appearance. Questions concerning alterations may be directed to the Unit Supply Technician.

905. Caring For and Wearing Uniforms

a. Image. Midshipmen must set and maintain the high standards of smartness in uniform appearance. The image reflected by your attention to detail is a key element in the public image of yourself and your service.

b. Cleanliness. Midshipman shall launder and dry clean uniforms at their own expense. Uniforms shall be clean, pressed, and presentable at all times. Accessories shall be clean, polished, and free from tarnish as appropriate.

c. Wear:

(1) Trousers. Trousers are to be worn at a length to cover the upper part of the rear of the shoe by approximately 1".

(2) Military creases. Military creases are formed by pressing two vertical creases in the front of the shirt, from the shoulder to seam through the center of each pocket to the bottom of the shirt, and three evenly spaced vertical creases in the back of the shirt, from the yoke seam to the bottom of the shirt. Sewn-in creases are not authorized.

(3) Specifics for Females.

(a) Coats. The length of women's bridge coats and raincoats correspond to the length of the uniform skirt.

(b) Earrings. One earring per ear (centered on earlobe) may be worn while in uniform. Earrings shall be 4mm-6mm gold ball (approximately 1/8"- 1/4"), plain with shiny or brushed matte finish, screw-on or with posts. Questions regarding earrings may be directed to your advisor.

(4) Specifics for Males. Navy Option midshipmen may wear a plain gold tie clasp when wearing the black tie if the clasp:

(a) Has a plain gold surface (either with or without a Navy anchor). The surface cannot be brushed gold, inscribed or decorated.

(b) Is approximately 2 1/2" x 1/4" in dimensions. While wearing the Service Dress Blue Uniform is not visible when the coat is worn.

(5) Accessories. Specifics on correct uniform wear are delineated in US Navy Uniform Regulations. In the case of any conflict between the guidance contained herein and the Uniform Regulations, the Uniform Regulations shall take precedence. Consult your advisor regarding the wear of any accessory item to ensure that it is appropriate.

(a) Glasses and Contact Lenses. No eccentric or faddish glasses are permitted. Conservative sunglasses are permitted, except in military formations, inspections, or parades. Plain, black, snugly worn retainer straps are authorized for safety only. Contact lenses must be a natural color and must not contain any unnatural design.

(b) Jewelry. Conservative jewelry is authorized and shall be in good taste while in uniform. Eccentricities or faddishness are not permitted. Jewelry shall not present a safety hazard and shall be worn within the following guidelines:

(1) Rings. While in uniform, only one ring per hand is authorized, plus a wedding or engagement ring set. Rings are not authorized for wear on thumbs.

(2) Necklaces. While in uniform, only one necklace may be worn and it shall not be visible. For safety, necklaces shall not be worn with the PT uniform.

(3) Wristwatches and Bracelets. While in uniform, only one of each may be worn. Ankle bracelets are not authorized while in uniform. For safety, bracelets shall not be worn with the PT uniform.

(c) Umbrellas. Plain black umbrellas may be carried in inclement weather and must be stowed properly while at the unit.

(d) Bags. Bags should be carried in the left hand to facilitate saluting. Bags, such as briefcases, gym bags, backpacks, lunch bags, suitcases, shall be hand carried with the following exceptions:

(1) Backpacks/gymbags may be worn in uniform when riding a bicycle or motorcycle, but shall be hand carried upon dismounting.

(2) Women's Navy handbags are worn over the left shoulder. Consult your advisor for questions related to appropriate purses or handbags.

(e) A seabag may be carried on the shoulders while in uniform.

(6) Other Articles. No articles shall protrude from or be visible on the uniform, including, but not limited to items such as pencils, pens, key chains, pins, combs, large wallets, or cigarettes.

906. Men's Uniforms (See U. S. Navy Uniform Regulations for uniforms not pictured.)

a. Service Dress Blue



REQUIRED BASIC UNIFORM COMPONENTS

1. Coat, Blue Service Dress
2. Shirt, White, Long Dress
3. Trousers, Blue Dress
4. Cap, Combination, White
5. Shoes, Black Dress
6. Socks, Black
7. Undershirt, White
8. Undershorts
9. Belt, Black, w/Gold Clip
10. Necktie, Black Four-in-Hand
11. Buckle, Gold
12. Ribbons

PRESCRIBABLE ITEMS

1. All-Weather Coat, Blue
2. Gloves, Black/White
3. Overcoat, Blue

OPTIONAL ITEMS

1. Cap, Garrison, Blue (w/sweater or black jacket only)
2. Cuff Links, Gold
3. Earmuffs (w/all-weather coat)
4. Jacket, Black
5. Overshoes
6. Bridge Coat
7. Scarf (w/outergarment only)
8. Sweater, V-Neck, Black
9. Tie, Clasp, Tack
10. Name/Identification Tag
11. Umbrella, Black

SERVICE DRESS BLUE IS AUTHORIZED FOR WEAR YEAR-ROUND AT ALL OFFICIAL FUNCTIONS OR SITUATIONS WHERE FORMAL DRESS, DINNER DRESS OR FULL DRESS EQUIVALENT ARE NOT PRESCRIBED AND CIVILIAN EQUIVALENT DRESS IS COAT AND TIE.

b. Service Dress White



REQUIRED BASIC UNIFORM COMPONENTS

1. Coat, White Service Dress
2. Trousers, White
3. Cap, Combination, White
4. Shoes, White Dress
5. Socks, White
6. Undershirt, White
7. Undershorts, White
8. Belt, White, w/Gold Clip
9. Buckle, Gold
10. Shoulder Boards (Hard)
11. Ribbons

PRESCRIBABLE ITEMS

1. Gloves, White
2. All-Weather Coat, Blue

OPTIONAL ITEMS

1. Earmuffs (w/outergarment only)
2. Overshoes
3. Scarf (w/outergarment only)
4. Umbrella, Black
5. Name/Identification Tag

SERVICE DRESS WHITE IS WORN AT ALL DESIGNATED OFFICIAL FUNCTIONS WHERE FORMAL DRESS, DINNER DRESS, OR FULL DRESS UNIFORMS ARE NOT PRESCRIBED AND CIVILIAN EQUIVALENT DRESS IS COAT AND TIE. ISSUED TO GRADUATING MIDSHIPMEN AND WORN UPON COMMISSIONING.

c. Dinner Dress Blue



REQUIRED BASIC UNIFORM COMPONENTS

1. Coat, Blue Service Dress
2. Shirt, White Dress
3. Trousers, Blue Dress
4. Cap, Combination, White
5. Shoes, Black Dress
6. Socks, Black
7. Undershirt, White
8. Undershorts
9. Belt, Black, w/Gold Clip
10. Necktie, Black Bow
11. Buckle, Gold
12. Miniature Medals (large medals not authorized)

PRESCRIBABLE ITEMS

1. Gloves, White
2. All-Weather Coat, Blue
3. Overcoat, Blue

OPTIONAL ITEMS

1. Shirt, White Formal
2. Overshoes
3. Cuff Links, Gold
4. Scarf (w/outergarment only)
5. Umbrella, Black

WEAR DINNER DRESS TO OFFICIAL FUNCTIONS WHEN CIVILIANS NORMALLY WEAR BLACK TIE. FOR MOST MIDSHIPMAN ACTIVITIES INVOLVING DINNER DRESS BLUE, THE COMBINATION COVER IS NOT WORN. NO NAME TAGS OR RIBBONS ARE WORN.

d. Summer White



REQUIRED BASIC UNIFORM COMPONENTS

1. Shirt, White Summer, Short Sleeve
2. Trousers, White
3. Cap, Combination, White
4. Shoes, White Dress
5. Socks, White
6. Undershirt, White
7. Undershorts, White
8. Belt, White, w/Gold Clip
9. Buckle, Gold
10. Shoulder Boards (Hard)
11. Ribbons

PRESCRIBABLE ITEMS

1. All-Weather Coat, Blue

OPTIONAL ITEMS

1. Earmuffs (w/outergarment only)
2. Jacket, Black
3. Overshoes
4. Bridge Coat
5. Scarf (w/outergarment only)
6. Name/Identification Tag
7. Sweater, V-Neck, Black
8. Umbrella, Black

NORMALLY WORN FOR OFFICE WORK, WATCH STANDING, LIBERTY, BUSINESS ASHORE AND WHERE PRESCRIBED AS UNIFORM OF THE DAY.

e. Service Khaki



REQUIRED BASIC UNIFORM COMPONENTS

1. Shirt, Khaki Service
2. Trousers, Khaki Service
3. Cap, Combination, Khaki
4. Shoes, Black Dress
5. Socks, Black
6. Undershirt, White
7. Undershorts
8. Belt, Khaki, w/Gold Tab
9. Buckle, Gold
10. Insignia, Collar
11. Ribbons
12. Name/Identification Tag

PRESCRIBABLE ITEMS

1. All-Weather Coat, Blue
2. Cap, Garrison, Khaki

OPTIONAL ITEMS

1. Earmuffs (w/outergarment only)
2. Jacket, Black
3. Jacket, Khaki Windbreaker
4. Overshoes
5. Bridge Coat
6. Scarf (w/outer garment only)
7. Shoes, Brown
8. Socks, Khaki
9. Sweater, V-Neck, Black
10. Umbrella, Black

NORMALLY WORN FOR OFFICE WORK. ISSUED TO ALL MIDSHIPMEN PRIOR TO FIRST CLASS CRUISE. ALL MIDSHIPMEN NOT YET ISSUED THIS UNIFORM WEAR WORKING KHAKI WHEN KHAKI UNIFORM IS PRESCRIBED. MIDSHIPMEN ISSUED THIS UNIFORM WEAR IT WHEN KHAKI UNIFORM IS PRESCRIBED UNLESS SPECIFICALLY DIRECTED.

f. Working Khaki



REQUIRED BASIC UNIFORM COMPONENTS

1. Shirt, Khaki Working Short Sleeve
2. Trousers, Khaki Working
3. Cap, Combination, Khaki
4. Shoes, Black Dress
5. Socks, Black
6. Undershirt, White
7. Undershorts
8. Belt, Khaki, w/Gold Clip
9. Buckle, Gold
10. Insignia, Collar
11. Name/Identification Tag

PRESCRIBABLE ITEMS

1. All weather Coat, Blue
2. Shirt, Working Long Sleeve
3. Cap, Garrison, Khaki
4. Overcoat, Blue
5. Shoes, Safety, Black

OPTIONAL ITEMS

1. Cap, Ball
2. Earmuffs (w/outergarment only)
3. Jacket, Black
4. Jacket, Khaki Windbreaker
5. Overshoes
6. Bridge Coat
7. Scarf (w/outer garment only)
8. Shoes, Brown
9. Socks, Khaki
11. Sweater, V-Neck, Black
12. Umbrella, Black

NORMALLY WORN BY UNDERCLASS MIDSHIPMEN WHEN KHAKI UNIFORM IS PRESCRIBED. ALSO NORMALLY WORN FOR SHIPBOARD WORK WITH SAFETY SHOES AND LONG SLEEVES. RIBBONS ARE NOT AUTHORIZED WITH THIS UNIFORM.

907. Women's Uniforms (See U. S. Navy Uniform Regulations for uniforms not pictured.)

a. Service Dress Blue



REQUIRED BASIC UNIFORM COMPONENTS

1. Coat, Blue Service Dress
2. Shirt, White, Dress
3. Trousers, Blue, Unbelted
4. Cap, Combination, White
5. Shoes, Black Service
6. Socks, Black
7. Undershirt, White
8. Brassiere
9. Underpants
10. Necktie, Black
11. Ribbons
12. Name/Identification Tag

PRESCRIBABLE ITEMS

1. Skirt, Blue, Unbelted (must wear hosiery and slip also)
2. All-Weather Coat, Blue
3. Shoes, Black Dress (with skirt)
4. Gloves, Black/White
5. Handbag, Black
6. Overcoat, Blue

OPTIONAL ITEMS

1. Overshoes
2. Earrings, Gold Ball
3. Umbrella, Black
4. Bridge Coat
5. Sweater, Blue V-Neck
6. Scarf (w/outer garment only)

SERVICE DRESS BLUE IS AUTHORIZED FOR WEAR YEAR-ROUND AT ALL OFFICIAL FUNCTIONS OR SITUATIONS WHERE FORMAL DRESS, DINNER DRESS OR FULL DRESS UNIFORMS ARE NOT PRESCRIBED AND CIVILIAN EQUIVALENT DRESS IS COAT AND TIE. CONSULT YOUR ADVISOR REGARDING WEAR WITH SKIRT TO ENSURE YOU MEET REGULATIONS.

b. Service Dress White



REQUIRED BASIC UNIFORM COMPONENTS

1. Coat, White Service Dress
2. Shirt, White Dress
3. Undershirt, White
4. Skirt, White Unbelted
5. Cap, Combination, White
6. Shoes, White Dress
7. Hosiery, Flesh Tone
8. Brassiere
9. Underpants
10. Slip
11. Necktie, Black
12. Ribbons

PRESCRIBABLE ITEMS

1. All-Weather Coat, Blue
2. Shoes, White Service (With trousers)
3. Handbag, White
4. Gloves, White
5. Trousers, White, Unbelted
6. Socks, White

OPTIONAL ITEMS

1. Overshoes
2. Earrings, Gold Ball
3. Umbrella, Black
4. Scarf (w/outer garment only)

WEAR SERVICE DRESS WHITE TO ALL OFFICIAL FUNCTIONS WHERE FORMAL DRESS, DINNER DRESS OR FULL DRESS UNIFORMS ARE NOT PRESCRIBED AND CIVILIAN EQUIVALENT IS COAT AND TIE. ISSUED TO GRADUATING MIDSHIPMEN AND WORN UPON COMMISSIONING.

c. Dinner Dress Blue



REQUIRED BASIC UNIFORM COMPONENTS

1. Coat, Blue Service Dress
2. Shirt, White
3. Trousers, Blue Unbelted
4. Cap, Combination, White
5. Shoes, Black Service
6. Brassiere
7. Underpants
8. Necktie, Black
9. Miniature Medals (large medals are not authorized.)

PRESCRIBABLE ITEMS

1. All-Weather Coat, Blue
2. Gloves, White
3. Overcoat, Blue
4. Skirt, Blue, Unbelted (must also wear hosiery, slip, and dress shoes)

OPTIONAL ITEMS

1. Overshoes
2. Earrings, Pearl/Gold
3. Umbrella, Black
4. Scarf (w/outer garment only)
5. Cuff Links, Gold

WEAR DINNER DRESS TO OFFICIAL FUNCTIONS WHEN CIVILIANS NORMALLY WEAR BLACK TIE. FOR MOST MIDSHIPMAN ACTIVITIES INVOLVING DINNER DRESS BLUE, THE COMBINATION COVER IS NOT WORN. NO NAME TAGS OR RIBBONS ARE WORN WITH THE MIDSHIPMAN DINNER DRESS BLUE. CONSULT YOUR ADVISOR REGARDING WEAR WITH SKIRT TO ENSURE YOU MEET REGULATIONS.

d. Summer White



REQUIRED BASIC UNIFORM COMPONENTS

1. Shirt, White, Short sleeve with epaulets
2. Trousers, White Belted
3. Cap, Combination, White
4. Shoes, White Service
5. Undershirt, White
6. Brassiere
7. Underpants
8. Socks, White
9. Belt, White, w/Gold Tip
10. Buckle, Gold
11. Shoulder Boards (Hard)
12. Ribbons
13. Name/Identification Tag

PRESCRIBABLE ITEMS

1. All-Weather Coat, Blue
2. Handbag, White

OPTIONAL ITEMS

1. Earmuffs (w/outer garment only)
2. Earrings, Gold, Ball
3. Jacket, Blue
4. Overshoes
5. Umbrella, Black
6. Sweater, Blue V-Neck
7. Scarf (w/outer garment only)

WEAR FOR OFFICE WORK. WATCH STANDING, LIBERTY, BUSINESS ASHORE AND WHERE PRESCRIBED AS THE UNIFORM OF THE DAY.

e. Service Khaki



REQUIRED BASIC UNIFORM COMPONENTS

1. Shirt, Khaki Service, Short Sleeve
2. Trousers, Khaki Service
3. Cap, Combination, Khaki
4. Shoes, Black Service
5. Socks, Black
6. Brassiere
7. Underpants
8. Undershirt, White
9. Belt, Khaki w/Gold Tip
10. Buckle, Gold
11. Insignia, Collar
12. Ribbons
13. Name/Identification Tag

PRESCRIBABLE ITEMS

1. Skirt, Khaki Summer (must wear hosiery, slip, and dress shoes also)
2. All-Weather Coat, Blue
3. Handbag, Black
4. Cap, Garrison, Khaki
5. Overcoat, Blue

OPTIONAL ITEMS

1. Beret
2. Earmuffs (w/outergarment only)
3. Earrings, Gold Ball
4. Jacket, Black
5. Shoes, Service, Brown
6. Socks, Khaki
7. Sweater, Black, V-Neck

NORMALLY WORN FOR OFFICE WORK. ISSUED TO ALL MIDSHIPMEN PRIOR TO FIRST CLASS CRUISE. ALL MIDSHIPMEN NOT YET ISSUED THIS UNIFORM WEAR WORKING KHAKI WHEN KHAKI UNIFORM IS PRESCRIBED. MIDSHIPMEN ISSUED THIS UNIFORM WEAR IT WHEN KHAKI UNIFORM IS PRESCRIBED UNLESS SPECIFICALLY DIRECTED. CONSULT YOUR ADVISOR REGARDING WEAR WITH SKIRT TO ENSURE YOU MEET REGULATIONS.

f. Working Khaki



REQUIRED BASIC UNIFORM COMPONENTS

1. Shirt, Khaki Working Short Sleeve
2. Trousers, Khaki Working
3. Cap, Combination, Khaki
4. Shoes, Black Dress
5. Socks, Black
6. Undershirt, White
7. Undershorts
8. Brassiere
9. Belt, Khaki, w/Gold Clip
10. Buckle, Gold
11. Insignia, Collar
12. Name/Identification Tag

PRESCRIBABLE ITEMS

1. All weather Coat, Blue
2. Shirt, Working Long Sleeve
3. Cap, Garrison, Khaki
4. Overcoat, Blue
5. Shoes, Safety, Black

OPTIONAL ITEMS

1. Cap, Ball
2. Earmuffs (w/outergarment only)
3. Jacket, Black
4. Jacket, Khaki Windbreaker
5. Overshoes
6. Bridge Coat
7. Scarf (w/outer garment only)
8. Shoes, Brown
9. Socks, Khaki
11. Sweater, V-Neck, Black

NORMALLY WORN BY UNDERCLASS MIDSHIPMEN WHEN KHAKI UNIFORM IS PRESCRIBED. ALSO NORMALLY WORN FOR SHIPBOARD WORK WITH SAFETY SHOES AND LONG SLEEVES. RIBBONS ARE NOT AUTHORIZED WITH THIS UNIFORM.

908. Unisex Uniforms (See U. S. Navy Uniform Regulations for uniforms not pictured.)

a. Coveralls



REQUIRED BASIC UNIFORM COMPONENTS

1. Coveralls
2. Cap, Garrison, Khaki
3. Shoes, Safety, Black
4. Socks, Black
5. Undershirt, White Crew Neck
6. Underpants
7. Buckle, Gold
8. Belt, Khaki, w/ Gold Tab

PRESCRIBABLE ITEMS

1. Insignia, Collar
2. Nametapes (Last Name and "U.S. Navy")

OPTIONAL ITEMS

1. Cap, Ball
2. Jacket, Khaki Windbreaker

AUTHORIZED FOR WEAR ON BOARD SHIPS ONLY. THIS UNIFORM IS ISSUED FOR AND USED DURING SUMMER TRAINING.

b. Camouflage Utility Uniform



REQUIRED BASIC UNIFORM COMPONENTS

1. Blouse, Woodland Camouflage
2. Trousers, Woodland Camouflage
3. Cover, Woodland Camouflage
4. Boots, Black Combat or Jungle
5. T-shirt, Green
6. Socks, Black
7. Boot Blousers
8. Under shorts
9. Brassiere (Female)

THIS UNIFORM WILL BE ISSUED AND PRESCRIBED AS NEEDED. NAMETAPES WILL BE PLACED AS REQUIRED. NO ECCENTRIC WATCHES ARE TO BE WORN. CONSULT THE MOI OR AMOI FOR WEAR OF THIS UNIFORM.

909. Insignia and Designators

a. Marine Designators. Additional uniform items are issued to Marine Option midshipmen. Consult the Supply Technician to ensure you have the proper gear. The placement of Marine Option insignia is covered in Figures 9-3, 9-4, and 9-5. The belt buckle shall be worn such that the Belt tip will extend from 2 to 4 inches beyond the belt buckle.

b. Year Group Insignia.

(1) Sleeve. Horizontal gold stripes, sewn on the left sleeve midway between the elbow and the shoulder, are worn on the Service Dress Blue Uniform. First class wear three; second class, two; third class, one; fourth class, none. Stripes are made of gold nylon braid 1-1/2 inches long and 1/8 inch wide with ¼ inch spacing. See Figure 9-1.

(2) Shoulder Boards. Shoulder Boards are worn on the male Service Dress White and both male and female Summer White uniforms. All Midshipmen wear shoulder boards on the bridge coat if worn.

(a) Navy. Proper devices for each class are illustrated in Figure 9-2. They are worn with the bitter end of the fouled anchor chain pointing aft. See Figure 9-3.

(b) Marine. Proper devices for each class are illustrated in Figure 9-2. They are worn so that the eagle's wings are parallel to the shoulder seam and the anchor points forward. See Figure 9-3.

(3) Collar Devices. Worn on the Working Khaki and Service Khaki uniforms. For insignia placement see Section 909.e.

(a) Navy. Worn such that bitter end of the fouled anchor chain points outboard. See Figure 9-4.

- MIDN 4th Class- Wear no collar devices
- MIDN 3rd Class- Wear Navy anchor on the right collar only.
- MIDN 2nd Class- Wear the Navy anchor on both collars.
- MIDN 1st Class- Wear Navy eagle and anchor on both collars.

(b) Marine. Worn such that the eagle's wings are parallel to the deck and the anchor points forward. See Figure 9-4.

- MIDN 4th Class- Wear no collar devices.
- MIDN 3rd Class- Wear Marine device on the right side only.
- MIDN 2nd Class- Wear Marine device on the left side and the Navy anchor on the right collar.
- MIDN 1st Class- Wear the Marine Corps insignia on both sides.

c. Midshipman Officer Insignia. For appropriate officer insignia for sleeves, shoulder boards and collars see Figure 9-6.

(1) Sleeve. Worn on both sleeves of the Service Dress Blue Coat centered on the outside of the sleeve 2" above and parallel to the edge of the cuff. The gold star is centered above the stripes with one ray pointing down and the point ¾" above the uppermost stripe.

(2) Shoulder boards. Both Navy and Marine Option wear the designated Midshipman Officer shoulder boards with a star in place of the anchor and Marine Corps insignia.

(3) Collar. Wear the rank insignia on both collars. For insignia placement see Section 909.e.

(4) All-Weather Coat and Khaki Jacket. Wear rank insignia on the shoulder straps. The insignia are the same as those worn on collars and are centered one inch away from and parallel to the shoulder seam.

d. Midshipman Non-commissioned Officer Insignia. Appropriate insignia for sleeves and collars:

(1) Sleeve. Worn on the outside right sleeve of the Service Dress Blue Coat halfway between the elbow and the shoulder. See Figure 9-7.

(2) Shoulder boards. Wear shoulder boards with the proper year and option insignia.

(3) Collar. Worn on Khaki Uniforms. For insignia placement see Section 909.e and Figure 9-5.

(a) Navy.

-MIDN 4th Class- Wear Navy eagle and anchor on the left collar.

-MIDN 3rd Class- Wear the eagle and anchor on the left collar and the Navy anchor on the right collar.

-MIDN 2nd Class- Wear the Navy anchor on the left collar and the eagle and anchor on the right collar.

-MIDN 1st Class- Wear eagle and anchor on both collars.

(b) Marine.

-MIDN 4th Class- Wear Navy eagle and anchor on the left collar.

-MIDN 3rd Class- Wear the eagle and anchor on the left collar and the Marine device on the right collar.

-MIDN 2nd Class- Wear the eagle and anchor on the right collar and the Marine device on the left collar.

-MIDN 1st Class- Wear Marine device on both collars.

e. Collar Insignia Placement

(1) Long Sleeve Working Khaki.

(a) Year Group Insignia: Pin insignia with the vertical axis of the insignia parallel to the collar edge, with the center of the insignia one inch from the collar edge. The top of the insignia should be one inch from the top of the collar. (Note: Long sleeve working khaki is only worn while underway on summer cruises.) See Figure 9-8.

(b) Midshipman Officer Insignia: Center the first bar one inch from the front edge and one inch below the upper edge of the collar. The upper edges of the bars are parallel to the upper edge of the collar. See Figure 9-8.

(2) Working (Short Sleeve) and Service Khaki

(a) Year Group Insignia: Center insignia one inch from the front and lower edges of the collar and position it with the vertical axis of the insignia along an imaginary line bisecting the angle of the collar point. See Figure 9-8.

(b) Midshipman Officer Insignia: Center insignia one inch from the front and lower edges of the collar and position it with the vertical axis of the insignia along an imaginary line bisecting the angle of the collar point. (Note: Midshipman Captains wear the insignia one-quarter inch from the lower and front edges of the collar. Pin with the vertical axis of the insignia along a line bisecting the collar point.) See Figure 9-8.

(c) Marine Option: The Eagle, Globe, and Anchor insignia is worn centered, one inch from the front edge of the collar, with the wings of the eagle parallel to the deck. Officer insignia is worn in the same manner, with vertical axis of the bars parallel to the deck. See Figure 9-8.

f. Service Dress Uniform Insignia. These devices are centered above the notch in the collar with the shank parallel to the collar seam. Male devices are $\frac{1}{2}$ inch above the notch and female devices one (1) inch above. Navy devices are large anchors; Marine devices are Marine prong and clutch insignia. Anchors are positioned with the lower end of the stock outboard and higher end of the stock inboard. See Figure 9-9.

g. Cap Insignia.

(1) Garrison Cap. The insignia is attached to the left side of the garrison cap, shank parallel to the front edge of the cover, 2" from the front edge. For males it is 1 $\frac{1}{2}$ " from the bottom edge of the cover to the center of the insignia. For females it is centered between the top and bottom edges of the cap apron. The Navy device is the 1" fouled anchor. The Marine device is the small USMC cap insignia. See Figure 9-10.

(2) Combination Cap. Worn on the front of the cap band. Navy Option wears the fouled anchor. Marine Option wears the large USMC cap insignia.

h. Miscellaneous.

(1) Name tags. Worn centered over the right breast pocket, $\frac{1}{4}$ " above the pocket for Navy Options and $\frac{1}{8}$ " above the pocket for Marine Options. Nametags are not worn when medals are prescribed. Nametags are also not worn during armed drill sessions.

(2) Ribbons and Medals. Worn centered over the left breast pocket, $\frac{1}{4}$ " above the pocket for Navy Options and $\frac{1}{8}$ " above the pocket for Marine Options. Medals shall be worn such that the upper edge of the lowest row of medals is approximately $\frac{3}{8}$ " from the upper edge of the pocket. The top edge of succeeding rows should be approximately 1" above the upper edge of the next row down. See Figure 9-11.

(3) Qualification Insignia. All Naval or Marine warfare insignia awarded to midshipmen are to be worn such that it is centered $\frac{1}{4}$ " above the left breast pocket or any row of ribbons. See Figure 9-11. Inform your advisor if you are awarded any such insignia so that you wear them properly.

(4) Drum and Bugle Corps Insignia. All members wear the insignia centered on the outside right sleeve of the Service Dress Blue Coat. The lower edge of the horn should be nine (9) inches from bottom of the sleeve. Consult your advisor on the wear of this insignia if the Drum and Bugle Corps is formed.

910. Grooming Standards for Midshipmen

a. General. Grooming standards are based on neatness, cleanliness, safety, military image, and the uniformed appearance of members of the Navy. The standards established herein are not intended to be overly restrictive nor designed to isolate midshipmen from society. If there is any conflict between the guidance contained herein and the respective service's Uniform Regulations, the Service's Regulations shall be followed. Consult your advisor regarding the contents of the Service Regulations to ensure you are within standards.

b. Males.

(1) Navy Option.

(a) Hair. Hair will be neat, clean and present a groomed appearance at all times. Hair above the ears and around the neck will be tapered from the lower hairline upward to at least $\frac{3}{4}$ " and outward no greater than $\frac{3}{4}$ " to blend with the hairstyle. Hair on the back of the neck may not touch the collar. Hair will be no longer than 4" and groomed so that it does not touch the ears or the collar, extend below eyebrows when headgear is removed, show under front edge of headgear, or interfere with proper wearing of the headgear. Bulk of the hair shall not exceed 2". Varying hairstyles, including Afro, are permitted, provided these styles meet the criteria of maximum length and bulk, tapered neck and sides, and do not interfere with the proper wearing of military headgear. Hair coloring must look natural and complement the individual. One (cut, clipped, or shaved) natural, narrow, fore and aft part is authorized.

(b) Sideburns. Sideburns shall be neatly trimmed and tapered in the same manner as the haircut. Sideburns will not extend below a point level with the middle of the ear, will be of even width (not flared), and will end with a clean-cut horizontal line.

(c) Beards and Moustaches. Midshipmen are not authorized to wear beards. If a moustache is worn it shall be well groomed and neatly trimmed at all times in order not to present a ragged appearance. The moustache will not go below a horizontal line extending across the corners of the mouth and no more than $\frac{1}{4}$ " beyond a vertical line drawn upward from the corners of the mouth. Consult your advisor if you intend to wear a moustache.

(d) Fingernails. Fingernails shall not extend past fingertips. They shall be kept clean.

(2) Marine Corps Option. Marine Corps Option grooming standards are contained in Marine Corps Order P1020.34. Consult the MOI or AMOI if you have any questions regarding this topic.

(a) Hair. Maximum hair length is 3".

(b) Sideburns. Sideburns will not extend below the top of the ear orifice.

(c) Moustaches. Moustaches will not extend beyond the edges of the mouth and beards are not permitted.

(d) Fingernails. Fingernails shall not extend past fingertips. They shall be kept clean.

c. Females.

(1) Hair.

(a) Haircuts and styles shall present a balanced appearance. Lopsided and extremely asymmetrical styles are not authorized. Ponytails, pigtailed, widely spaced individual hanging locks, and braids, which protrude from the head, are not authorized. Spit curls or "ringlets" that fall below the bottom of the ear are not permitted while in uniform.

(b) Hair may touch, but may not fall below a horizontal line level with the back bottom edge of the collar. Long hair will be neatly arranged so that it does not interfere with the wearing of the cover. A maximum of two braids, neatly and inconspicuously fastened to the head, are permitted. Hair shall not show under the front brim of the combination or garrison caps. No portion of the bulk of the hair as measured from the scalp will exceed approximately 2". Multiple braids are authorized; see U. S. Navy Uniform Regulations for specifics. Consult your advisor to ensure you meet standards.

(c) Barrettes, rubber bands, and hairpins are permitted, but they must match the hair color as closely as possible. They should not be extremely large or noticeable. A maximum of two barrettes may be used when pinning up hair. Additional bobby pins or rubber bands matching hair color may be used to hold hair in place, if necessary. Fabric elastics and colored rubber bands/pins are not authorized.

(d) Hairnets shall not be worn unless authorized for a specific type of duty.

(2) Cosmetics. Cosmetics may be applied in moderation and in good taste so that colors blend with natural skin tone and enhance natural features. Care should be taken to avoid an artificial appearance. Eye shadow, nail polish, and lipstick colors shall be conservative and complement the individual. Long false eyelashes shall not be worn in uniform.

(3) Fingernails. Fingernails shall be kept clean and not extend beyond ¼" measured from the fingertip.

911. Civilian Attire

a. General. The wearing of civilian attire, like the service uniform, implies a dedication to professionalism. Naval personnel shall ensure that their dress and personal appearance are appropriate for the occasion and will not discredit the Naval Services. Specific guidance on civilian clothing is contained in each service's Uniform Regulations, and those regulations shall be followed in the case of a conflict between them and the guidance contained herein.

b. At the Unit. When at the unit building, civilian attire will be clean and free of holes, rips, or stains. Trousers and shorts will be free of holes, with no fraying at the seams. Footwear will be in good taste and appropriate for the occasion. Pool slides, "flip-flops" or footwear intended for showering shall not be worn with civilian attire, unless medically prescribed. Clothing appropriate for physical training will be worn in that setting only. Personnel are allowed to wear physical training attire during the activity and in transit to or from that activity.

c. Unsuitable Attire. Wearing or displaying clothing, jewelry, tattoos, etc. depicting marijuana, any other controlled substance or advocating drug abuse, displaying profane, offensive, or subversive material, or messages that imply affiliation with gangs or subversive groups is prohibited at all times. Consult your advisor to ensure that your clothing meets standards.

Figure 9-4: Year Group Collar Insignia
 (R = Right Side, L = Left Side)

Navy Option

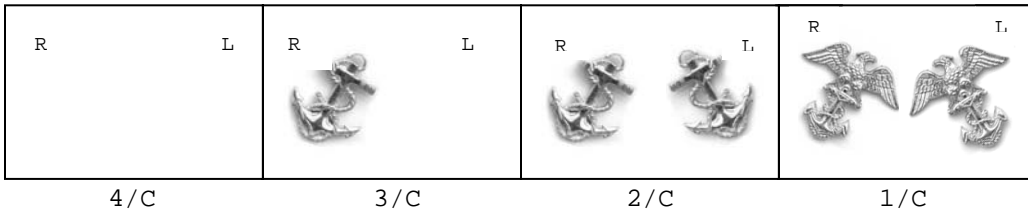

Marine Option

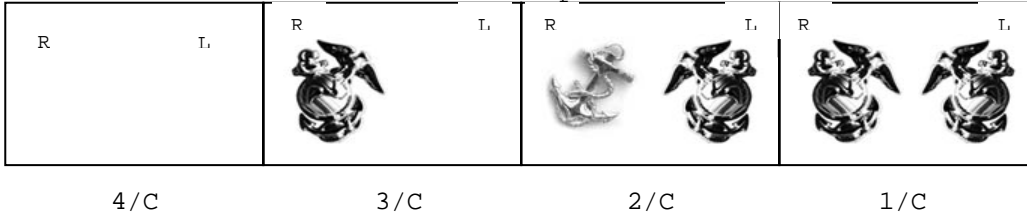
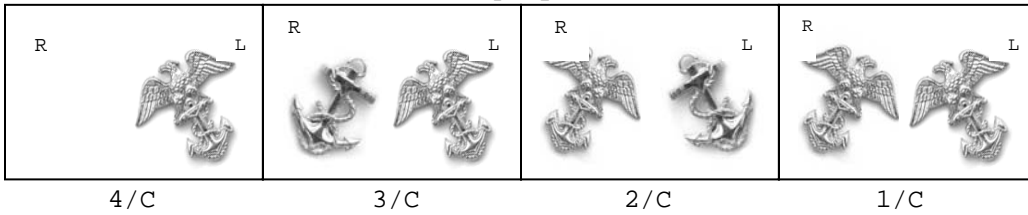

Figure 9-5: Midshipman Non-Commissioned Officer Collar Insignia
 (R = Right Side, L = Left Side)

Navy Option



Marine Option

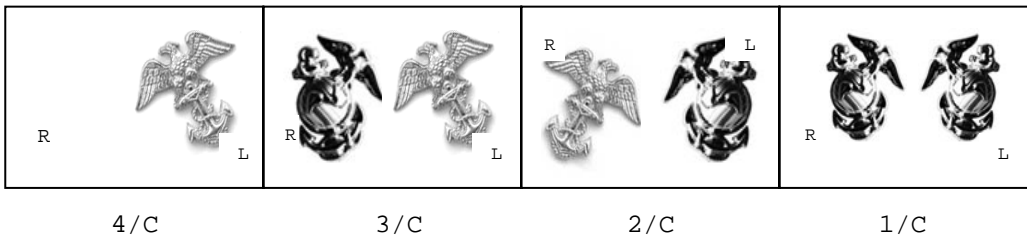

Figure 9-6: Midshipman Officer Insignia
 (SEE SECTION 305 FOR OFFICER RANK ASSIGNMENT)

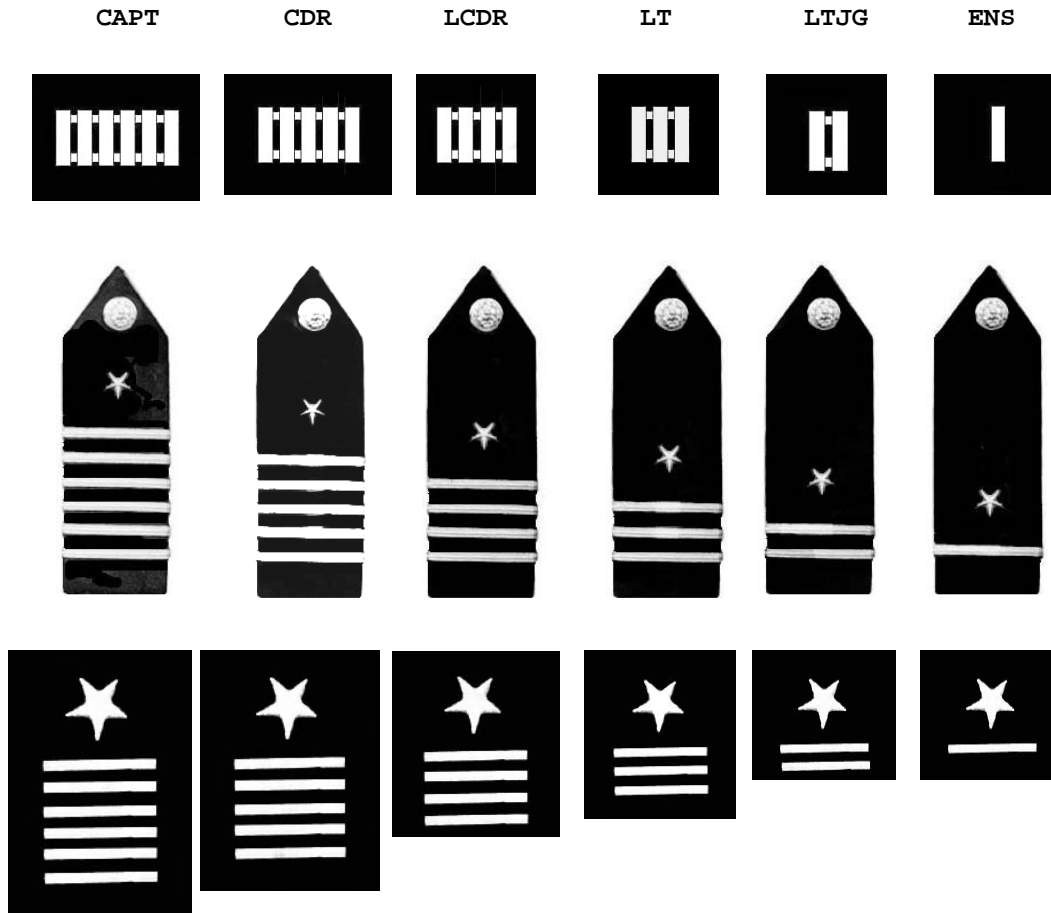

Figure 9-7: Midshipman Non-Commissioned Officer Sleeve Insignia
 (SEE SECTION 306 FOR NCO RANK ASSIGNMENT)

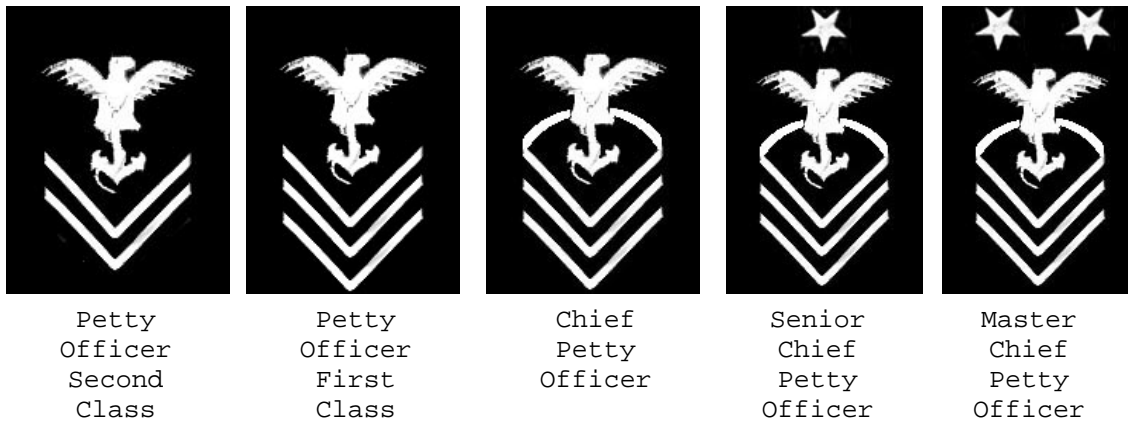
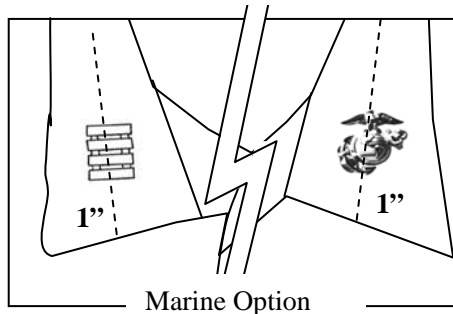
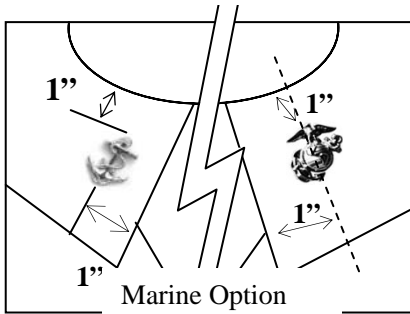
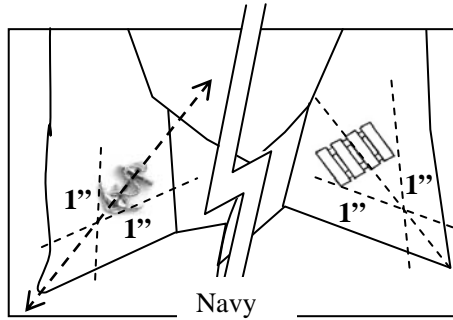
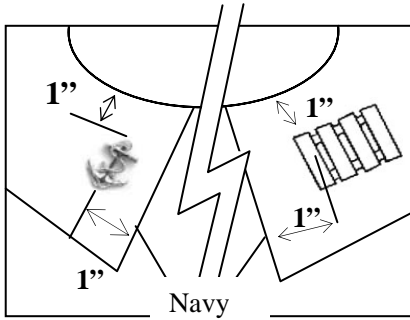

Figure 9-8: Collar Insignia Placement

Long-Sleeve Working Khaki

Short-Sleeved Khaki



(Marine Option Midshipmen: Consult the MOI for specifics regarding wear on Coveralls and Camouflage uniforms.)

Figure 9-9: Service Dress Blue/White Collar Insignia

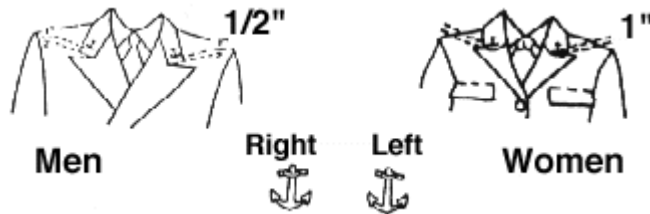

(Device is centered between inboard and outboard edges of lapel for both Navy and Marine Options.)

Figure 9-10: Garrison Cap Devices

(DEVICE ON FEMALE CAP IS CENTERED BETWEEN TOP AND BOTTOM EDGES OF CAP.)

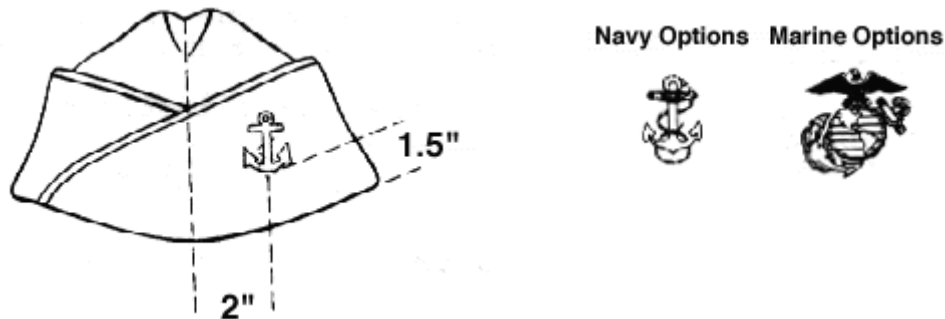
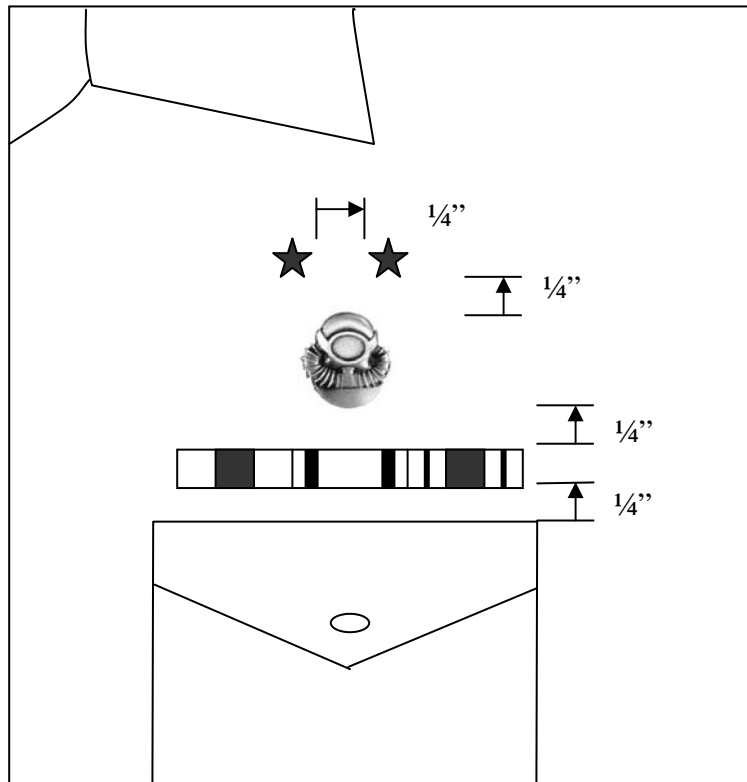
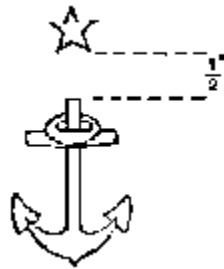

Figure 9-11: Proper Placement of Awards and Insignia

Academic Achievement Stars.

(1) On Service Dress Blue uniforms, stars shall be worn centered 1/2 inch above the lapel anchors with two rays of the star pointing down.

(2) On Service Dress White, Summer White, Khaki, and Winter Blue uniforms, the star shall be worn 1/4 inch and centered above the left breast pocket with two rays pointing down. When other personal decorations are worn above the left breast pocket, the academic star will be worn 1/4 inch and centered above the top most personal decorations on the left breast pocket with two rays pointing down.



CHAPTER 10
ESSENTIAL KNOWLEDGE FOR NROTC STUDENTS

The Sailor's Creed (For All Navy Students):

I am a United States Sailor.

I will support and defend the Constitution of the United States of America
and I will obey the orders of those appointed over me.

I represent the fighting spirit of the Navy and those who have gone before me
to defend freedom and democracy around the world.

I proudly serve my country's Navy combat team with Honor, Courage, and
Commitment.

I am committed to excellence and the fair treatment of all.

The Rifleman's Creed (For All Marine Students):

This is my rifle. There are many like it, but this one is mine.

It is my life. I must master it as I must master my life.

Without me my rifle is useless. Without my rifle, I am useless.

I must fire my rifle true. I must shoot straighter than the enemy who is
trying to kill me. I must shoot him before he shoots me. I will.

My rifle and I know that what counts in war is not the rounds we fire, the
noise of our burst, or the smoke we make. We know that it is the hits that
count. We will hit.

My rifle is human, even as I am human, because it is my life.

Thus, I will learn it as a brother. I will learn its weaknesses, its
strengths, its parts, its accessories, its sights and its barrel. I will keep
my rifle clean and ready, even as I am clean and ready. We will become part
of each other.

Before God I swear this creed. My rifle and I are the defenders of my
country. We are the masters of our enemy. We are the saviors of my life.

So be it, until victory is America's and there is no enemy.

Important Birthdays in the Naval Services

The Birthday of the United States Navy:

13 October 1775

The Birthday of the United States Marine Corps:

10 November 1775

The Birthday of Naval Aviation:

8 May 1911

The Birthday of Marine Corps Aviation:

27 December 1913

The Birthday of the Navy Nurse Corps:

13 May 1908

Famous Firsts in the Naval Services

The first Admiral in the Navy: Rear Admiral David Glasgow Farragut, USN
The first Commandant of the Marine Corps: MAJ Samuel Nicholas, USMC
The first Chief of Naval Operations: Admiral William Benson, USN
The first General Officer in the Marine Corps: BG Archibald Henderson, USMC
The first Secretary of the Navy: The Honorable Benjamin Stoddert
The first 4-Star Admiral in the Navy: ADM George Dewey, USN
The first Naval Aviator: LT Gordon Ellyson, USN
The first Marine Aviator: 2LT Alfred Cunningham, USMC
The First Aircraft Carrier: USS Langley (CV-1)
The first Nuclear-Powered Submarine: USS Nautilus (SSN-571)

Service Songs

Navy: Anchor's Aweigh

Stand, Navy, out to sea, fight, our battle cry,
We'll never change our course, so vicious foe steer shy.
Roll out the TNT, anchor's aweigh. Sail on to victory
And sink their bones to Davy Jones, Hooray!

Anchor's aweigh my boys, anchor's aweigh.
Farewell to foreign shores, we sail at the break of day, of day.
Through our last night ashore, drink to the foam,
Until we meet once more, here's wishing you a happy voyage home.

Blue of the mighty deep; gold of God's great sun,
Let these our colors be till all of time be done, be done.
On seven seas we lean Navy's stern call:
Faith, courage, service true, with honor over, honor over, all.

Service Songs

Marine Corps: *The Marine Hymn*

From the Halls of Montezuma
To the shores of Tripoli,
We fight our country's battles
In the air, on land, and sea.
First to fight for right and freedom,
And to keep our honor clean,
We are proud to claim the title
Of United States Marine.

Our flag's unfurl'd to every breeze
From dawn to setting sun;
We have fought in every clime and place
Where we could take a gun.
In the snow of far-off northern lands
And in sunny tropic scenes,
You will find us always on the job-
The United States Marines.

Here's health to you and to our Corps
Which we are proud to serve;
In many a strife we've fought for life
And never lost our nerve.
If the Army and the Navy
Ever look on Heaven's scenes,
They will find the streets are guarded
By United States Marines.